



INSTALLATION INSTRUCTIONS FOR THE DUCT SMOKE DETECTOR

These are Installation Instructions (DWG.# HA-06-094) for the Duct Housing customized as follows:

- SD505-DUCT** Duct Housing with the SD505-APS Analog Photoelectric Smoke Sensor*
- SD505-DUCTR** Duct Housing with the SD505-APS Analog Photoelectric Smoke Sensor & Relays*
- SD505-DTS-K** Remote Test Switch

I. LOCATION REQUIREMENTS

Duct Smoke Detector Location

Requirements: To prevent false alarms the detectors should not be mounted in areas of extreme high or low temperatures, in areas where high humidity exist, or in areas where duct air may contain gases or excess dust. The duct detector should, when possible, be located a minimum of six duct widths downstream from a source of turbulence (bends, inlets, or deflection plates). At these locations, air flow is less turbulent and the air/smoke mixture should be more homogenous. Refer to NFPA 90A, 72, and 101 for more information. See Figure 1A and 1B.

Exception: Where it is physically impossible to locate the duct detector accordingly, the duct detector can be positioned closer than six duct widths, but as far as possible from inlets, bends, or deflection plates.

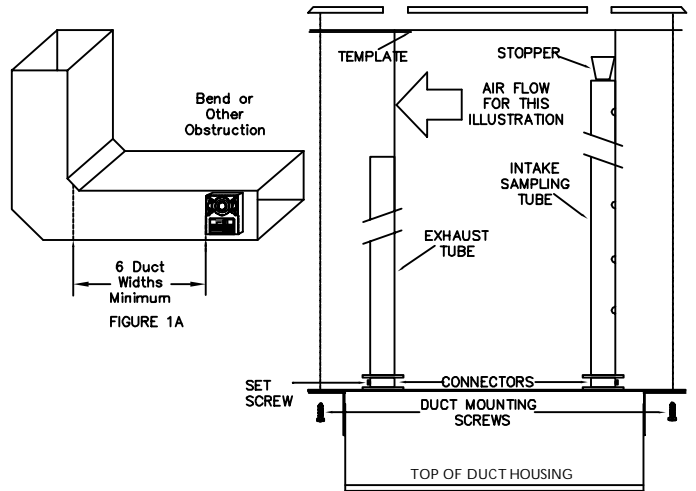

FIGURE 1B: DUCT HOUSING MOUNTING

II. MOUNTING THE DETECTOR

A. DUCT PREPARATION

1. Remove paper backing from mounting template AP 121 (packaged in installation kit) and affix to duct at desired location.
2. Using template as a guide, drill 4 mounting holes (3/32" diameter) for duct mounting screws (4 #12 x 1/2" sheet metal screws packaged in installation kit). Drill or punch holes for sampling tubes in air ducts (1-3/8" diameter), using template as a guide. Clean all holes.

B. VERIFY AIR FLOW AND DIRECTION

The Duct Detectors are designed for use in ducts where the air velocities are from 300 to 4000 feet per minute. Verify this by checking specifications of installation and if necessary, use an Anlor Model 6000P velocity meter (or equivalent) to check the air velocity. See Figure 2 for sampling tube orientation to air flow direction.

C. SAMPLING TUBE ASSEMBLY (See Figure 2)

The sampling tubes may be ordered to a desired length or ordered in one of 3 standard lengths and cut per requirements. The intake sampling tube consists of a piece of steel piping with a series of holes drilled the entire length of the tube and should extend the entire width of the duct. The holes must be facing into the air flow (see Figure 2). The exhaust tube consists of a piece of steel piping approximately 7-1/2" long.

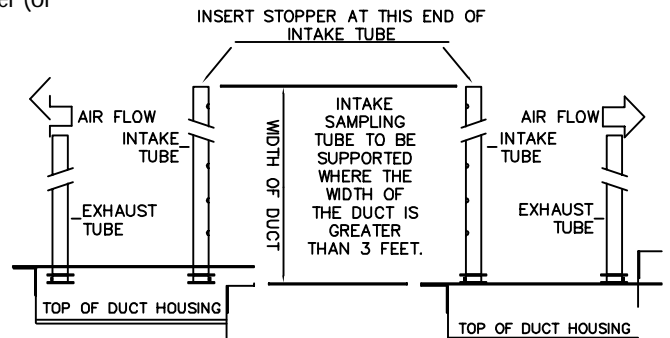

FIGURE 2 SAMPLING TUBE ORIENTATION

INTAKE SAMPLING TUBES STANDARD LENGTHS:

- SD505-T2 For duct widths of 1.0' to 2.5'
- SD505-T5 For duct widths of 2.5' to 5.0'
- SD505-T10 For duct widths of 5.0' to 10.0'

1. Cut the intake sampling tube to the desired length.
2. Firmly insert the stopper (packaged in installation kit) in the end of the INTAKE sampling tube.

D. MOUNT SAMPLING TUBES (See Figure 2)

1. Sampling tube connectors are equipped with set screws, which allow the tubes to be mounted only in directions shown in Figure 2. Establish proper orientation considering airflow direction.
2. Insert intake and exhaust tubes into connectors, align set screw to set screw hole in tubes and tighten firmly.

E. MOUNT THE DUCT HOUSING (See Figure 1B & 2)

Move duct housing/sampling tube assembly to desired location. Use 4 mounting screws (4 #12 x 1/2" sheet metal screws, packaged in installation kit) to secure the housing to the air duct.

F. VERIFY AIR SAMPLING (See Figure 3)

To verify proper sampling of air, use a Dwyer Model 4000 differential pressure gauge (or equivalent). See Figure 3 for gauge connections. The pressure differential between input sampling tube and exhaust tube should be greater than 0.01" of water and less than 1.2" of water.

SPECIFICATIONS

| SPECIFICATIONS | RATING | |
|------------------------------|-----------------------------|---|
| | SD505-DUCT | SD505-DUCTR |
| Alarm Relay Contact Rating | | 10A @ 24VDC 10A @ 115VAC 10A @ 240VAC |
| Trouble Relay Contact Rating | | 2.5A @ 30VDC |
| Operating Voltage | | 24VDC |
| Aux. Power Input Current | | 20mA Standby 62mA Alarm |
| SLC Input Current | 0.5mA | 0.5mA |
| Maximum SLC Resistance | 50 Ohms | 50 Ohms |
| Operating Temperature | 32F ~ 100F | 32F ~ 100F |
| Humidity | 10% ~ 85% RH Non-Condensing | 10% ~ 85% RH Non-Condensing |
| Air Velocity Rating | 300 ~ 4000 ft./min. | 300 ~ 4000 ft./min. |

III. ELECTRICAL INSTALLATION

A. GENERAL INFORMATION

Wiring must conform to applicable local codes, ordinances and regulations covering these types of devices. Wire the detectors according to the engineering drawings for the particular job requirements. These detectors are not intended for open area protection, nor should they be used for open air protection. Refer to NFPA 90A and NFPA 72 for general and additional information on Duct Smoke Detectors concerning operation and installation. Terminals are suitable for up to #14 gauge wire.

B. DETECTOR WIRING

1. With power source de-energized and the smoke detector not installed, wire all connections per engineering drawings. Refer to the applicable figures below depending on your duct housing model number.
2. With all wiring in place, install the detector head.
3. Energize the duct detector.

C. WIRING DIAGRAMS

SD505-DUCT WIRING DIAGRAM

The SD505-DUCT is not a self-contained sensor. This product is compatible only with fire alarm control panels that utilize Silent Knight's Digital Communications Protocol.

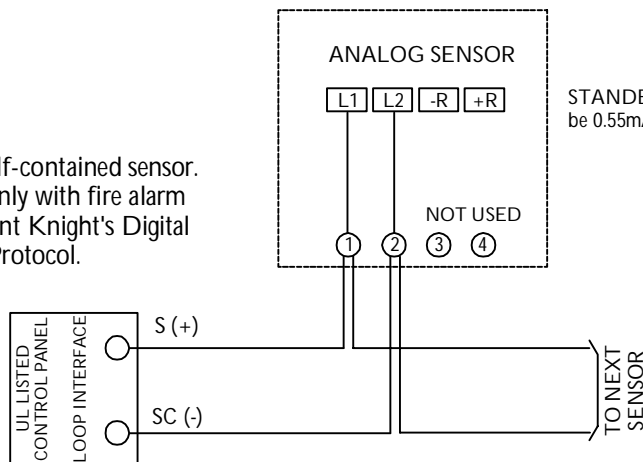

SD505-DUCTR WIRING DIAGRAM

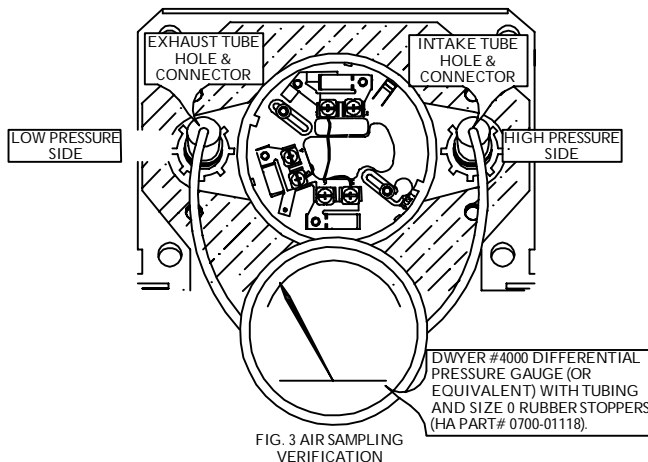
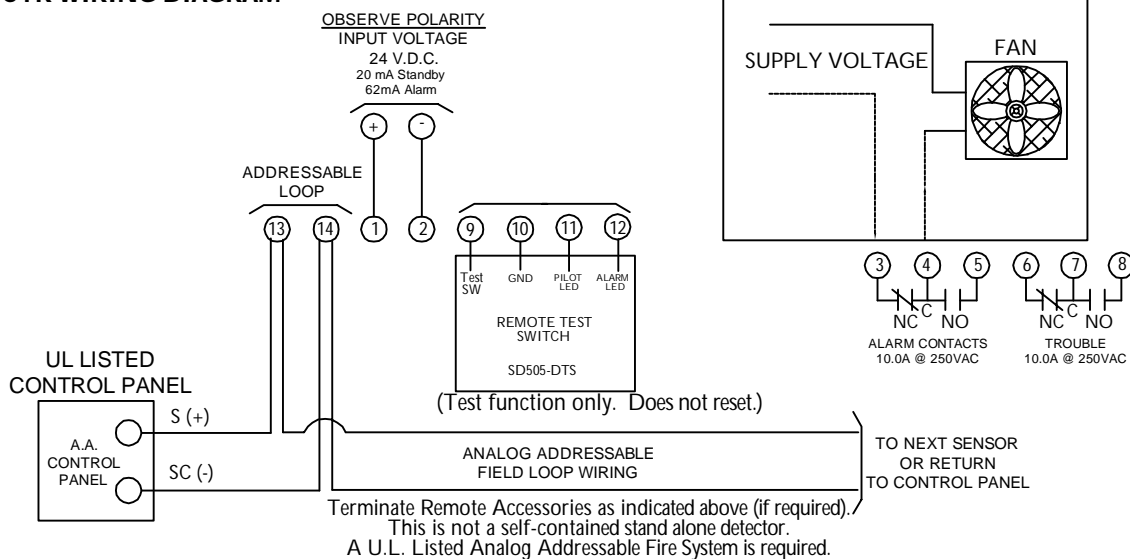

SD505-DUCTR AND SD505-DTS-K WIRING CONNECTIONS

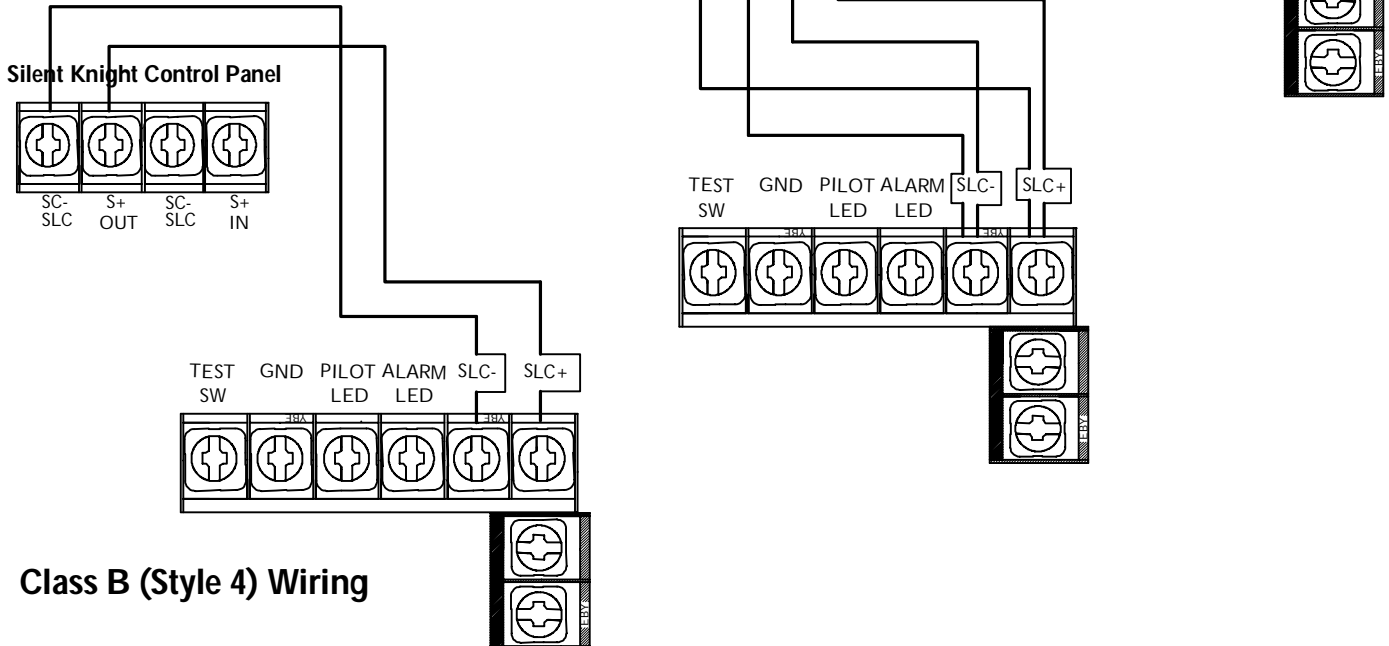
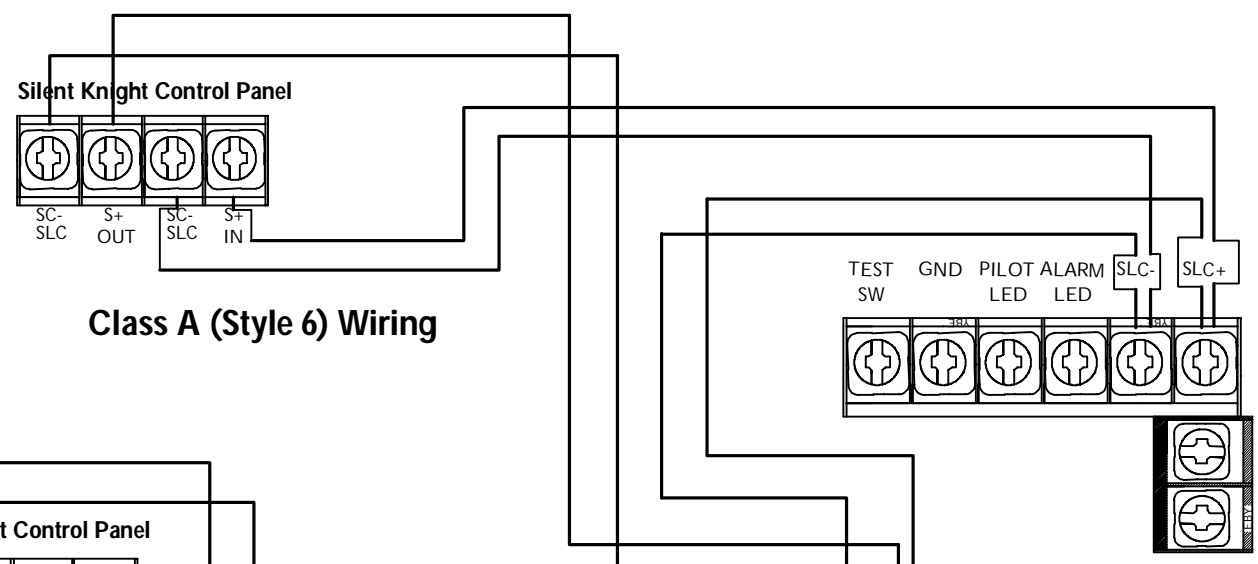
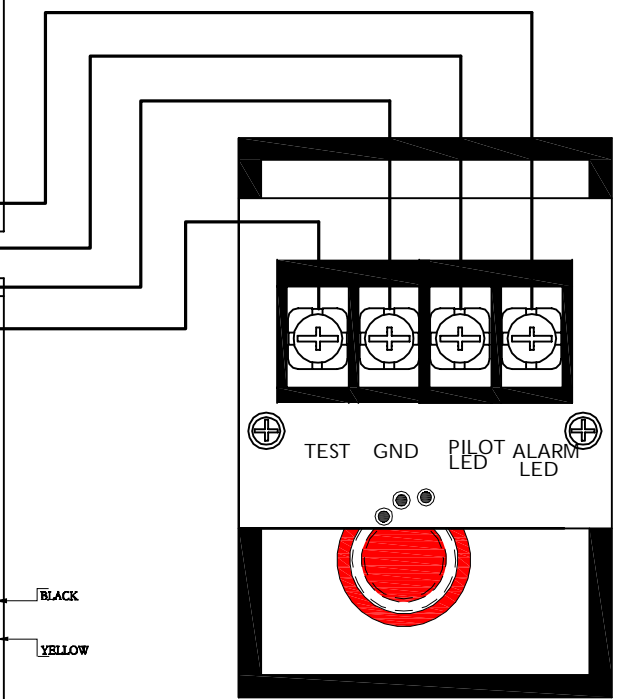
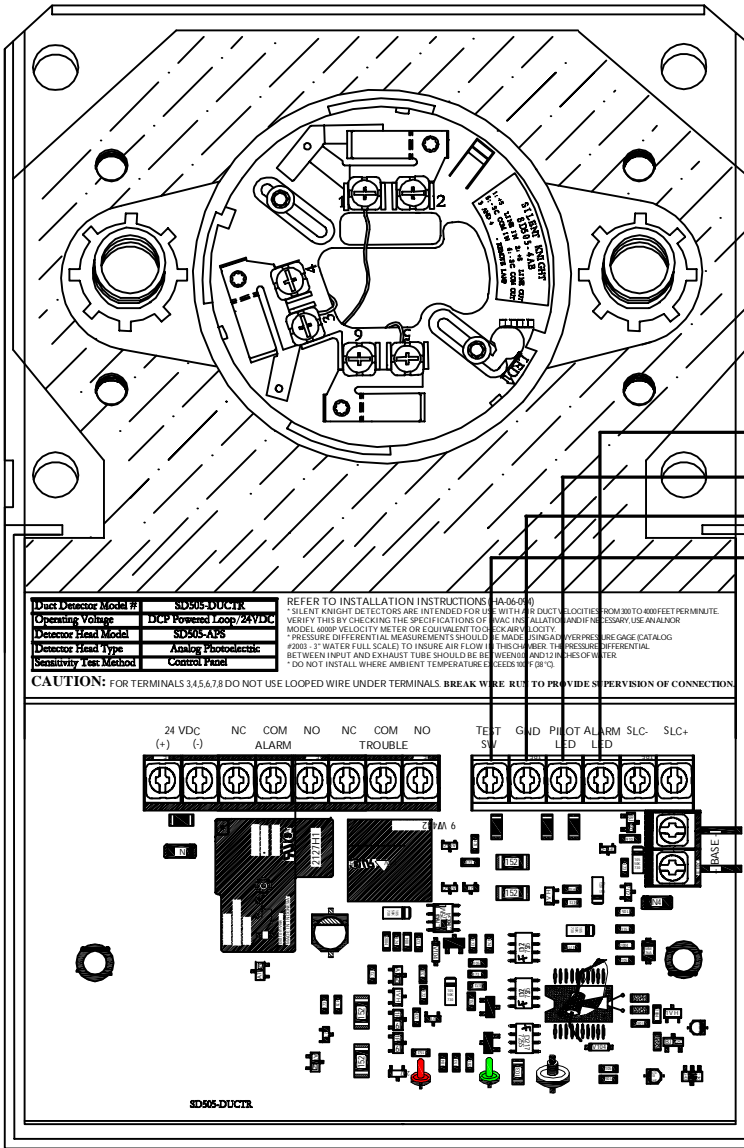

by Honeywell
12 Clintonville Road
Norford, CT 06472