



SILENT KNIGHT

5495 Distributed Power Module

**Installation and
Operations Manual**

Part Number 151161 Rev K

Contents

Section 1

Introduction	1
---------------------------	---

Section 2

UL Requirements	2
------------------------------	---

2.1 ULC Requirements	2
----------------------------	---

Section 3

System Overview	3
------------------------------	---

3.1 Terminal Descriptions and Electrical Ratings	3
3.2 Signal Input Terminals	4
3.3 Notification Appliance Circuit Terminals	5

Section 4

Installation	6
---------------------------	---

4.1 Mounting	6
4.1.1 Preventing Water Damage	6
4.2 Wire Routing	7
4.3 Current Requirements (Standby and Alarm)	8
4.3.1 Current Drawn From Host Panel	8
4.3.2 Current Drawn from Battery	8
4.3.2.1 CAN/ULC-S527	8
4.4 Connecting the 5495 to a Control Panel	10
4.4.1 Common Trouble Relay	11
4.5 Notification Appliance Wiring	11
4.5.1 Class A Supervised Wiring	11
Class A Output Notification Circuits	11
Class A Supervised Input Circuits	12
4.5.2 Class B Supervised Wiring	12
Class B Output Notification Circuits	12
Class B Supervised Input Circuits	13
4.6 Ground Fault Detection Enable/Disable Jumper	13
4.7 Battery Connection	14
4.7.1 Battery Connection in ULC Installations	15
4.8 DIP Switch Settings	15
4.8.1 Selecting the Standard Input/Output Configurations	16
4.8.1.1 Input/Output Configurations That Select ANSI Temporal-Coded Outputs	17
4.8.2 Selecting Synchronized Output Configurations	18
4.8.2.1 Selecting Synchronized Faraday Configurations	18
4.8.2.2 Selecting Synchronized Gentex Configurations	18
4.8.2.3 Selecting Synchronized System Sensor Configurations	19

4.8.2.4	Selecting Synchronized Wheelock Configurations	19
4.8.2.5	Selecting Synchronized AMSECO Configurations	19
4.8.3	Setting the Loss of AC Delay	20
4.8.4	Setting the Auxiliary Output	20

Section 5

Sample Applications

5.1	Notification Power Applications	21
5.2	Non-Resettable Power Application	23
5.3	Door Holder Application	24

Section 6

Troubleshooting

6.1	LEDs	25
6.2	Trouble Conditions	26
6.3	Earth Fault Resistance	27
6.4	Removing and Replacing the Control Panel	28
6.4.1	Removing the Control Panel	28
6.4.2	Replacing the Control Panel	28

Appendix A

UL Listed Notification Appliances

A.1	Notification Appliances	29
-----	-------------------------------	----

Silent Knight Fire Product Warranty and Return Policy

Section 1

Introduction

The 5495 is a notification appliance circuit and auxiliary power expander that provides up to 6 amps of filtered, 24 volt power for powering notification appliances and auxiliary devices. The 5495 provides its own AC power connection, battery charging circuit, and battery connections. Used with security and fire alarm control panels, the 5495 enables you to connect and distribute power to many more devices than your panel may normally allow.

- **Input Configurations**

The 5495 has two optically isolated signaling inputs that provide the signal connection from the main control panel to the 5495 (see Section 3.2 for more details).

- **Output Configurations**

The 5495 has four power-limited notification appliance circuits that can be configured in various combinations of Class A and Class B circuits (see Section 3.3 for details).

- **Auxiliary Power Configurations**

The 5495 has a dedicated, power-limited, auxiliary output that can be configured in two different ways. The auxiliary output can either be non-resettable (always on), or configured to switch off during the AC power failure to conserve the battery standby power. When the auxiliary power is configured to switch off, there is a 30 second delay before the auxiliary power is turned off after the AC power fails (see Section 4.8.4 for details).

- **Form C Trouble Relay**

The 5495 includes a general trouble relay that will de-energize for any trouble situation. (see Section 4.4.1 for details).

- **Earth Fault Detection**

The 5495 monitors for earth faults to the system power or system ground. When detected, the system de-energizes the trouble relay and the input supervision relays (see Section 5.2 for details).

- **ANSI Temporal Code**

The 5495 provides two configuration options that will drive outputs with the ANSI temporal code if the inputs are on constantly (see Section 4.8.1 for details).

- **Supports Synchronized appliances**

The 5495 provides configuration options that will eliminate the need for synchronized modules when using AMSECO, Faraday, Gentex, System Sensor, or Wheelock synchronization appliances.

Section 2

UL Requirements

When installed in accordance with NFPA 70 and NFPA 72 standards, the 5495 can be connected to UL Listed devices.

The 5495 is also listed to meet UL Standard 864 and power limiting requirements.

The 5495 is compatible with any UL listed control unit utilizing reverse polarity supervised notification appliance circuits, using 24 VDC regulated outputs.

2.1 ULC Requirements

Install in accordance with CE 22.1 and ULC S524. For the installation to comply with ULC, the Silent Knight 5612 module must be installed between the battery and control as describe in Section 4.7.1.

Section 3

System Overview

CAUTION

Each output circuit is rated at 3 amps. DO NOT OVERLOAD. Overloading a circuit will cause it to shut down (power limit). The circuit will automatically reset once you remove the overload condition.

3.1 Terminal Descriptions and Electrical Ratings

Terminal #	Description	Ratings
TB1		
1	AC (black--“hot”)	120 VAC 60 Hz, 2A
2	Earth Ground	
3	AC (white--“neutral”)	
TB2		
1	Auxiliary Power (-)	27.4 VDC 3.0 amps
2	Auxiliary Power (+)	
3	Notification 4 Output (-)	27.4 VDC 3.0 amps
4	Notification 4 Output (+)	
5	Notification 3 Output (-)	27.4 VDC 3.0 amps
6	Notification 3 Output (+)	
7	Notification 2 Output (-)	27.4 VDC 3.0 amps
8	Notification 2 Output (+)	
9	Notification 1 Output (-)	27.4 VDC 3.0 amps
10	Notification 1 Output (+)	
11	Normally Closed contact	2.5 A @ 250 VAC or 2.5 A @ 30 VDC
12	Common	
13	Normally Open contact	
14	Input 2	9 - 30 VDC
15	Input 2 (-)	
16	Input 2 (+)	
17	Input 1	9 - 30 VDC
18	Input 1 (-)	
19	Input 1 (+)	

Although each output is rated for 3 amps, the total current draw from the 4 outputs and the auxiliary power must not exceed 6 amps.

3.2 Signal Input Terminals

Terminals 14 through 19 are polarized signal input terminals. They provide the signaling connection from the main panel to the 5495. See Figure 4-2 for more details.

The main panel supervises its notification appliance circuits used for communicating with the 5495 the same way it supervises ordinary notification appliance circuits. The signal inputs on the 5495 monitor the polarity of the voltage coming from the main panel's notification appliance circuits to determine when to operate the notification appliance circuits on the 5495. The 5495 emulates the trouble behavior of a normal notification appliance circuit by interrupting the EOL supervision current for internal or output trouble conditions on the 5495.

Note that the 5495 will accurately sense the polarity of the main panel's notification appliance circuits to drive the outputs whether or not the supervision connection is intact. The following situations will disconnect the EOL supervision at the signal inputs and indicate a trouble condition:

- Low AC power
- Low Battery condition
- Earth ground fault to the system power or system ground
- Auxiliary output power-limited condition
- EOL supervision trouble or power-limited condition at an output

Trouble conditions will not necessarily occur for both inputs when the trouble is specific to a particular output. Only the signal input controlling the output circuit that is in trouble will indicate a trouble condition. Below are examples where both inputs do NOT indicate trouble for a trouble occurring at only one output circuit.

Example 1: If input 1 controls all four outputs, a fault on any output will cause input 1 to indicate trouble. The fault does not affect input 2.

Example 2: If input 1 controls outputs 1 and 2, and input 2 controls outputs 3 and 4, a fault condition on output 3 or 4 will cause input 2 to indicate trouble. The fault does not affect input 1.

Note: *Once the inputs are driven with forward polarity to activate the outputs, the main control panel will not be able to sense trouble conditions through its notification appliance circuit connected to the 5495 input circuits. Use the 5495 trouble relay when it is necessary to monitor trouble conditions and active alarm conditions at the same time.*

Section 6 explains the significance of each trouble condition in more detail.

3.3 Notification Appliance Circuit Terminals

Terminals 3 through 10 are the notification appliance circuit output terminals. Each of the four circuits are rated at 3 amps, although you can only draw a total of 6 amps from the 5495. The 5495 outputs are short-circuit protected (power limited) according to UL 864 standards. Overcurrent indicators are yellow LEDs. The output voltage can vary depending on the load and input voltage.

The four power-limited NAC outputs can be configured as follows:

- Four Class B circuits
- Two Class A circuits
- One Class A and two Class B circuits
- Class B, ANSI temporal-coded circuits
- Faraday synchronized outputs
- Gentex synchronized outputs
- System Sensor synchronized outputs
- Wheelock synchronization outputs
- AMSECO synchronized outputs

One or both 5495 signal inputs control the NAC outputs, depending on the specific configuration setup. Possible configurations for the 5495 are:

For Option:	These Inputs:	Control These Outputs:	As:
1	Input 1	All outputs	Class B circuits
2	Input 1 or Input 2	Outputs 1, 2, 3, and 4	Class B ANSI temporal-coded circuits
3	Input 1 Input 2	Outputs 1 and 2 Outputs 3 and 4	Class B circuits Class B circuits
4	Input 1 Input 2	Output 1 Outputs 2, 3, and 4	Class B circuits Class B circuits
5	Input 1	Outputs 1-2 and 3-4	Class A circuit pairs
6	Input 1 Input 2	Outputs 1 and 2 Outputs 3 and 4	Class B ANSI temporal-coded circuits Class B circuits
7	Input 1 Input 2	Outputs 1-2 Outputs 3-4	Class A circuit pair Class A circuit pair
8	Input 1 Input 2	Outputs 1-2 Outputs 3 and 4	Class A circuit pair Class B circuits
9	Input 1 (Strobe Control) Input 2 (Audio Control)	All outputs	Class A or Class B Faraday Sync. Output
10	Input 1 (Strobe Control) Input 2 (Audio Control)	All outputs	Class A or Class B Gentex Sync. Output
11	Input 1 (Strobe Control) Input 2 (Audio Control)	All outputs	Class A or Class B System Sensor Sync. Output
12	Input 1 (Strobe Control) Input 2 (Audio Control)	All outputs	Class A or Class B Wheelock Sync. Output
13	Input 1 (Strobe Control) Input 2 (Audio Control)	All outputs	Class A or Class B Amseco Sync. Output

You can select which input controls which output, and which inputs are Class A and Class B using the 7-position DIP switch on the printed circuit board. Section 4.8 for DIP switch settings.

Section 4

Installation

Before installing the 5495, the AC input must first be wired into the building's main electrical power through the TB1 terminals (see Figure 4-2). Shut off the electrical power to the 5495, and then complete the general installation of the 5495 using the information in this section.

4.1 Mounting

Mount the 5495 in locations that meet the following temperature and humidity requirements. Do not expose the panel to conditions outside these ranges. For use in indoor, dry environments.

Temperature	0° C-49° C (32° F-120° F)
Humidity	10%-93% at 30° C (86° F) noncondensing

When mounting on interior walls, use appropriate screw anchors in plaster. When mounting on concrete, especially when moisture is expected, first attach a piece of 3/4-inch plywood to the concrete surface. Attach the 5495 to the plywood.

4.1.1 Preventing Water Damage

Water damage to the fire system can be caused by moisture entering the cabinet through the conduits. Conduits that are installed to enter the top of the cabinet are most likely to cause water problems. Installers should take reasonable precautions to prevent water from entering the cabinet. Water damage is not covered under warranty.

4.2 Wire Routing

To avoid induced noise (transfer of electrical energy from one wire to another), keep input wiring isolated from high current output and power-limited wiring. Induced noise can interfere with telephone communication or even cause false alarms. Avoid pulling a single multiconductor cable for the entire system. Instead, separate high current input/output from low current. Separate power-limited from non-power-limited wiring. Non-power-limited wiring must be enclosed in conduit.

Wiring within the cabinet should be routed around the perimeter of the cabinet. It should not cross the printed circuit board where it could induce noise into the sensitive microelectronics or pick up unwanted RF noise from the switching power supply circuit.

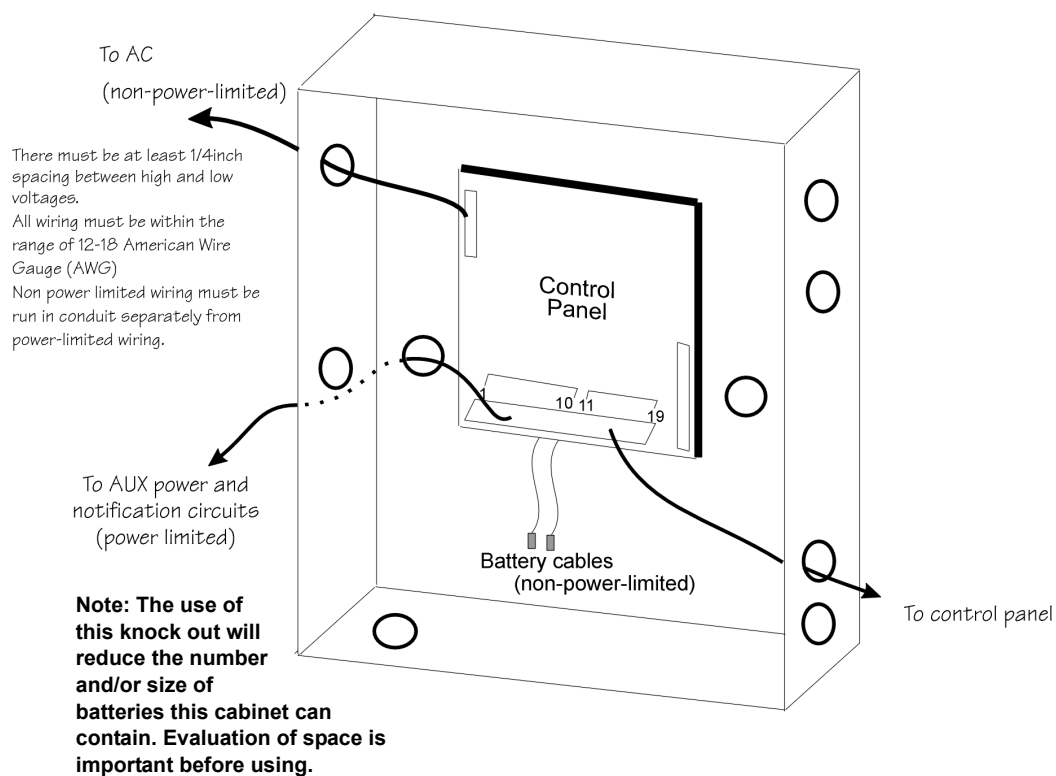

Figure 4-1 Sample Wire Routing

4.3 Current Requirements (Standby and Alarm)

4.3.1 Current Drawn From Host Panel

Table 4-1 shows the 5495 current draw requirements from the main control panel when the panel's notification appliance circuit is in alarm. The current draw from the main panel when it is supervising the 5495 is the same current draw that would be present when the main panel supervises an ordinary notification appliance circuit.

Table 4-1: Alarm Current Drawn From Main Control Panel

	Panel Voltage	Current	
Alarm Current (for typical voltages) drawn from main panel's notification appliance circuits.	12 VDC	6.5 mA	
	24 VDC	One input circuit:	15 mA
		Both input circuits:	30 mA

4.3.2 Current Drawn from Battery

Batteries used with the 5495 must not exceed 35 AH. Batteries larger than 7 AH will not fit into the 5495 cabinet and must be housed in the AB-33 Accessory Battery Cabinet. See Section 4.7 for battery installation.

The following is the maximum current draw from the auxiliary power terminals for standby calculations. These currents assume 24 or 60 hours of standby time, followed by 5 minutes of maximum alarm current.

- 195 mA for 24 Hour Standby Current
- 39 mA for 60 Hours of Auxiliary Standby Current

The above numbers were calculated assuming the use of 7 AH batteries at 100% of rated capacity.

The total current of the 5495, plus all items powered from it, must not exceed 6 A when the panel is in alarm. Use Table 4-2 to ensure that the current does not exceed 6 A and, that the desired amount of standby is possible for the battery intended for use with the 5495.

4.3.2.1 CAN/ULC-S527

Per CAN/ULC-S527, the maximum current draw from the auxiliary power terminals for standby calculations is 39 mA for 24 hours standby current. The current assumes 24 hours of standby time, followed by 30 minutes of maximum alarm current.

Table 4-2: Battery Calculation Worksheet

	Device	Number of Devices	Current per Device		Standby Current	Alarm Current	
	<i>For each device use this formula:</i>	<i>This column</i>	<i>X</i>	<i>This column</i>	=	<i>Current per number of devices.</i>	
	5495 Distributed Power Module (Current draw from battery)	1	Standby:	75 mA	75 mA		
			Alarm:	205 mA		205 mA	
A	5495 Current				75 mA	205 mA	
	Auxiliary Devices	<i>Refer to device manual for current ratings.</i>					
			Alarm/Standby	mA	mA	mA	
			Alarm/Standby	mA	mA	mA	
			Alarm/Standby	mA	mA	mA	
			Alarm/Standby	mA	mA	mA	
B	Auxiliary Device Current				mA	mA	
	Notification appliances	<i>Refer to device manual for current ratings.</i>					
			Alarm:	mA	0 mA	mA	
			Alarm:	mA	0 mA	mA	
			Alarm:	mA	0 mA	mA	
			Alarm:	mA	0 mA	mA	
C	Notification Appliance Current				0 mA	mA	
D	Total current ratings of all devices in system (line A + line B + line C)				mA	mA	
E	Total current ratings converted to amperes (line D x .001):				A	A	
F	Number of standby hours (24 or 60 for NFPA 72, Chapter 1, 1-5.2.5). 24 Hrs. for NBC, section 3.2.7.8				H		
G	Multiply lines E and F. Total standby AH				AH		
H	Alarm sounding period in hours. In accordance with NBC and ULC. (For example, 5 minutes = .0833 hours, or for ULC installations 30 minutes = 0.5 hours.)					H	
I	Multiply lines E and H. Total alarm AH					AH	
J	Add lines G and I. Total standby and alarm AH				AH		
K	Multiply line J by 1.20. (20% extra insurance to meet desired performance) Total ampere-hours required				AH		

4.4 Connecting the 5495 to a Control Panel

Figure 4-2 shows the general layout of the 5495 PC board. This section also provides specific wiring details for accessories.

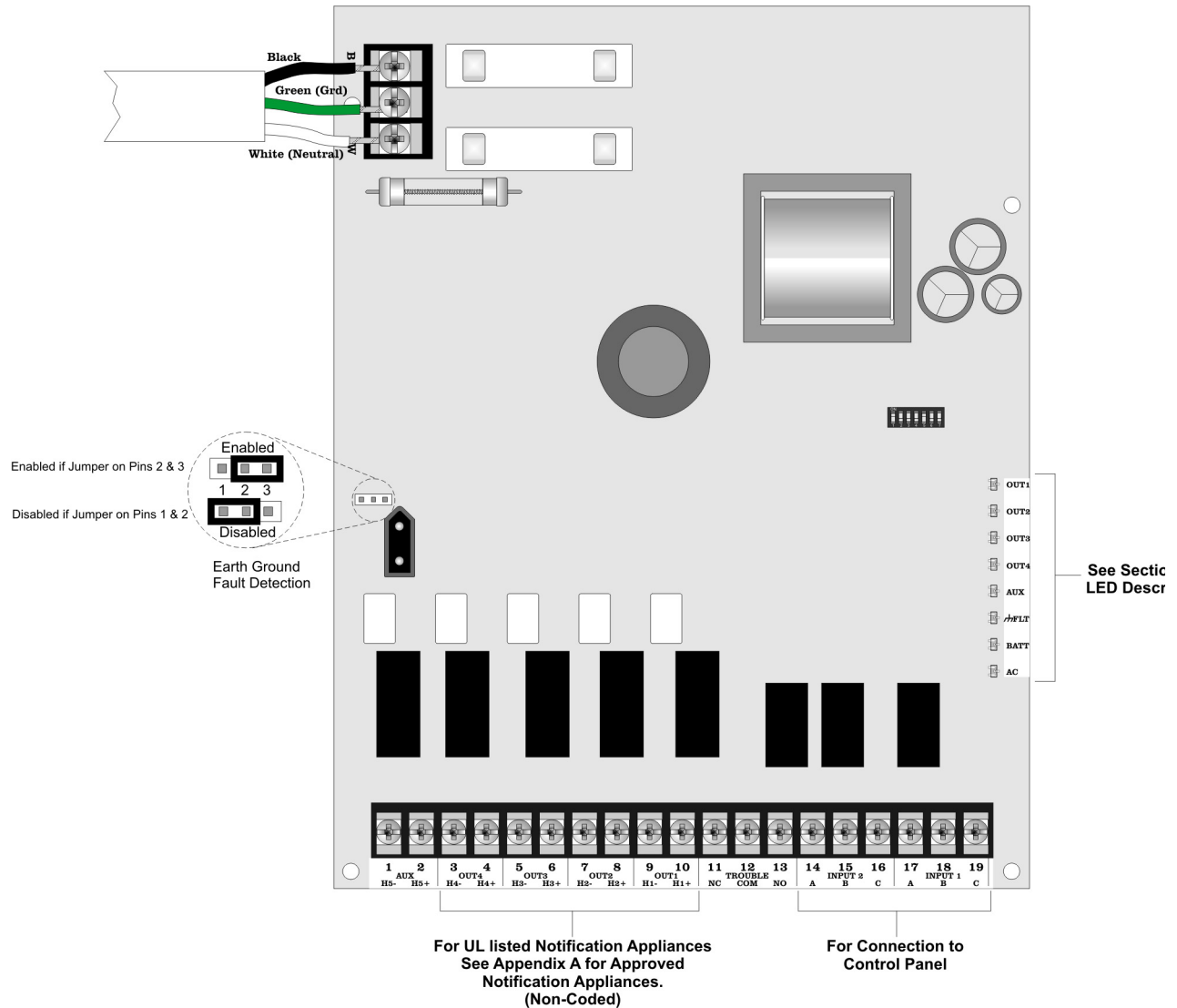

Figure 4-2 The Model 5495 PC Board Layout

Consult the installation manual for specific wiring information for the control panel being used.

4.4.1 Common Trouble Relay

The 5495 has a Form C trouble relay built into Terminals 11-13. The relay provides a normally open and a normally closed contact, both of which are rated at 2.5A. The trouble relay will deactivate under any trouble condition.

A typical application of the trouble relay is to connect the 5495 normally closed (N.C.) contacts in series with the EOL supplied with the fire alarm control panel. This will cause a trouble on the fire alarm control panel when the 5495 opens its trouble contacts.

Note: The N.C. contact is the contact that is closed when the 5495 has power and there are no trouble conditions.

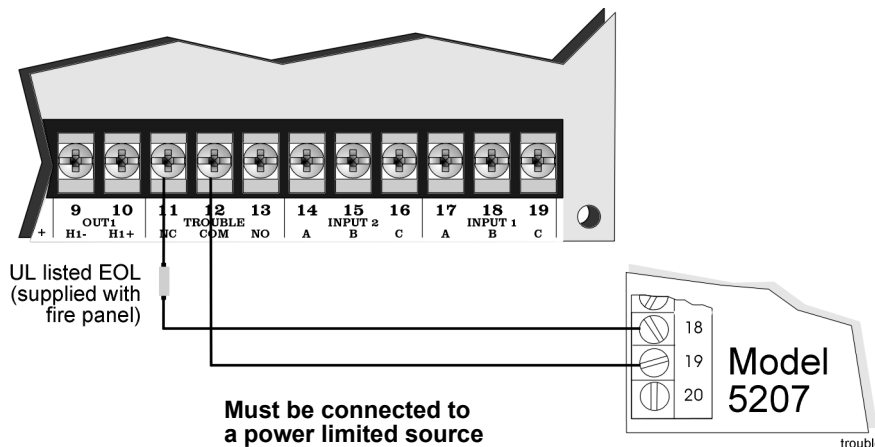

Figure 4-3 Trouble Relay Connection Example

4.5 Notification Appliance Wiring

Note: Not all devices can use the sync feature. Be sure to check Appendix A to ensure the device you have chosen will work with this feature.

4.5.1 Class A Supervised Wiring

Figure 4-4 shows how to wire for Class A input and output supervision. Use in/out wiring methods for proper supervision. (Refer to Appendix A for notification appliances compatible with the 5495.)

Class A Output Notification Circuits

The configuration shown in Figure 4-4 shows two, 3 A devices wired as Class A. When using the outputs as Class A circuits, loop the wiring back to the corresponding circuit pair. For Class A wiring, no external EOL is necessary since it is built into the 5495 board.

Class A Supervised Input Circuits

The configuration shown in Figure 4-4 shows Class A supervised wiring from a fire alarm control panel to the 5495 board. Pay close attention to the polarities when wiring a panel to the 5495 and follow these requirements:

- When wiring to Terminal 18 on the 5495, you must use two separate wires. Do not loop a single wire or twist two conductors together.
- Do not use notification appliances on Class A circuits connected to a 5495 for input. The 5495 will detect voltage across the input circuits, but is not designed to pass the added current load from notification appliances.

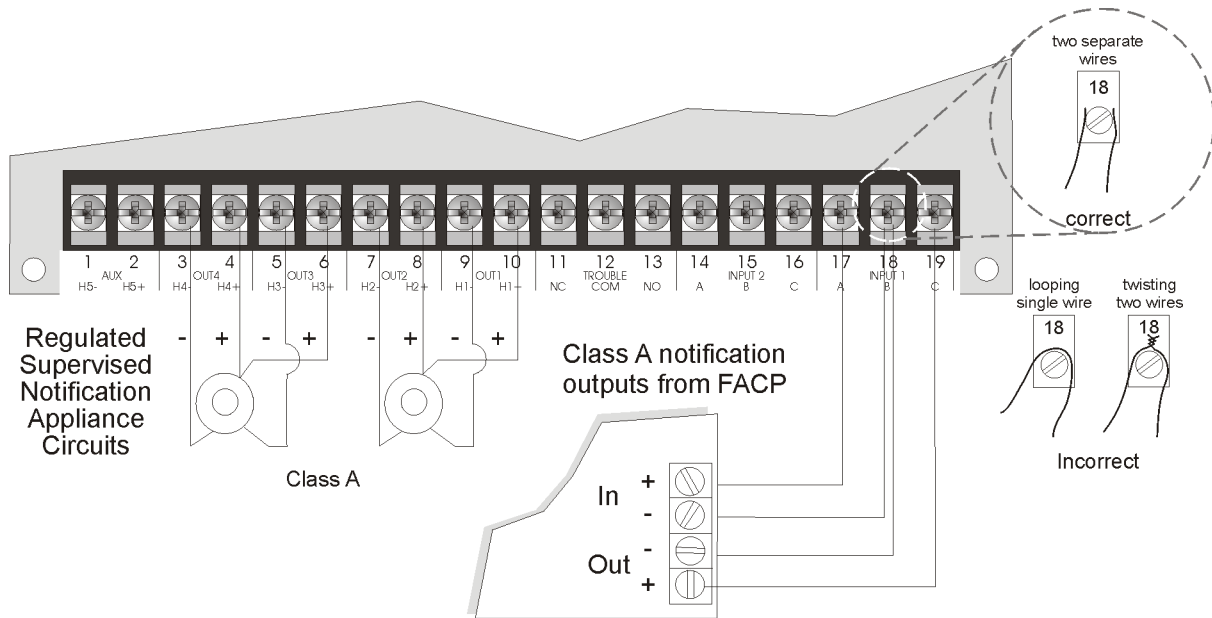

For system supervision of terminals 15 and 18, do not use looped wire under the terminals. Break the wire run to provide supervision of connections.

Figure 4-4 Class A Supervised Input/Output Connections

4.5.2 Class B Supervised Wiring

Figure 4-5 shows how to wire for Class B input and output supervision. Use in/out wiring methods for proper supervision (Refer to the Appendix for notification appliances approved for use with the 5495.)

Class B Output Notification Circuits

Figure 4-5 shows four, 1.5 A devices wired as Class B.

Place a 4.7k ohm EOL resistor (provided) at the end of each circuit to enable supervision when using all outputs as Class B notification appliance circuits. The 4.7k EOLs must be wired to the terminals whether or not you are using all output terminals.

Class B Supervised Input Circuits

Figure 4-5 shows Class B supervised wiring from a fire alarm control panel to the 5495.

Use an EOL resistor as shown to enable notification appliance circuit input supervision. Some panels use EOLs that have a different value from the 4.7k ohm EOL resistor used by the 5495. In this case, the EOL must be UL listed for the fire alarm control panel (not the 5495).

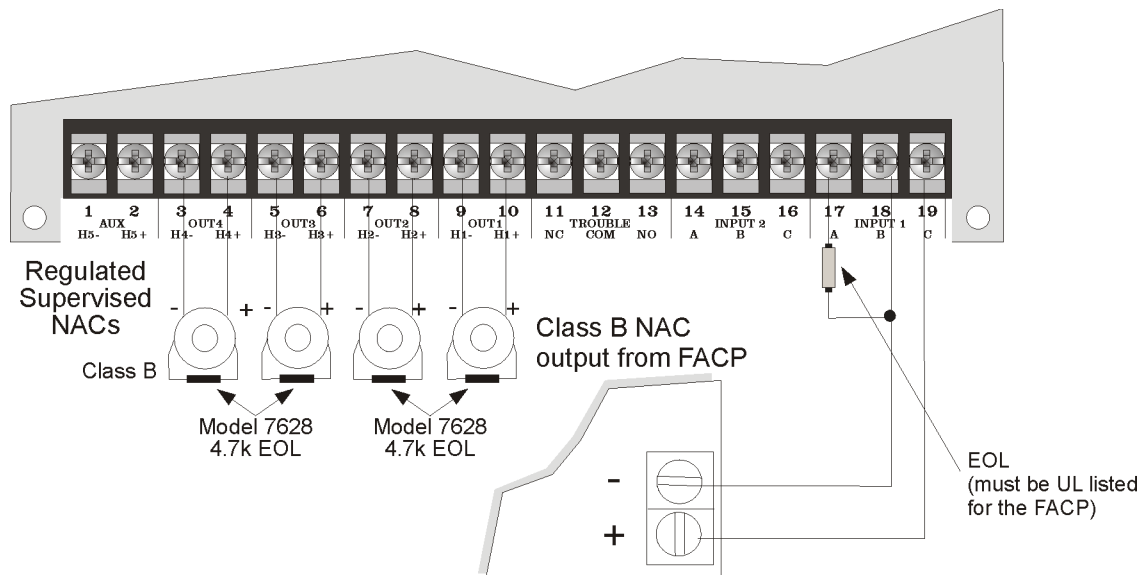

Figure 4-5 Class B Supervised Input/Output Connections

4.6 Ground Fault Detection Enable/Disable Jumper

In some cases the ground fault detection feature on the 5495 may interfere with the ground fault detection feature of the main control panel in the system. To disable the ground fault detection feature on the 5495, place the jumper block on J1, across Pins 1 and 2 (see Figure 4-2).

4.7 Battery Connection

Use two 12 VDC, 7 AH gel cell batteries inside the 5495 cabinet. For batteries larger than 7 AH (not to exceed 35 AH) use the AB-33 Accessory Battery Cabinet. It is recommended that you replace the batteries every five years. The following steps and diagram explain how to connect the batteries.

1. Connect the black wire to the negative (-) side of Battery #1.
2. Connect the jumper wire provided (PN 140694) from the positive (+) side of Battery #1 to the negative side of Battery #2.
3. Connect the red wire to the positive (+) side of Battery #2.

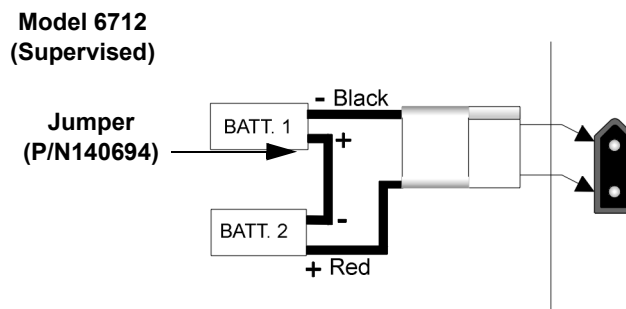

Figure 4-6 Battery Connection

4.7.1 Battery Connection in ULC Installations

For ULC installations, a 5612 module must be installed between the batteries and the control as shown in Figure 4-7.

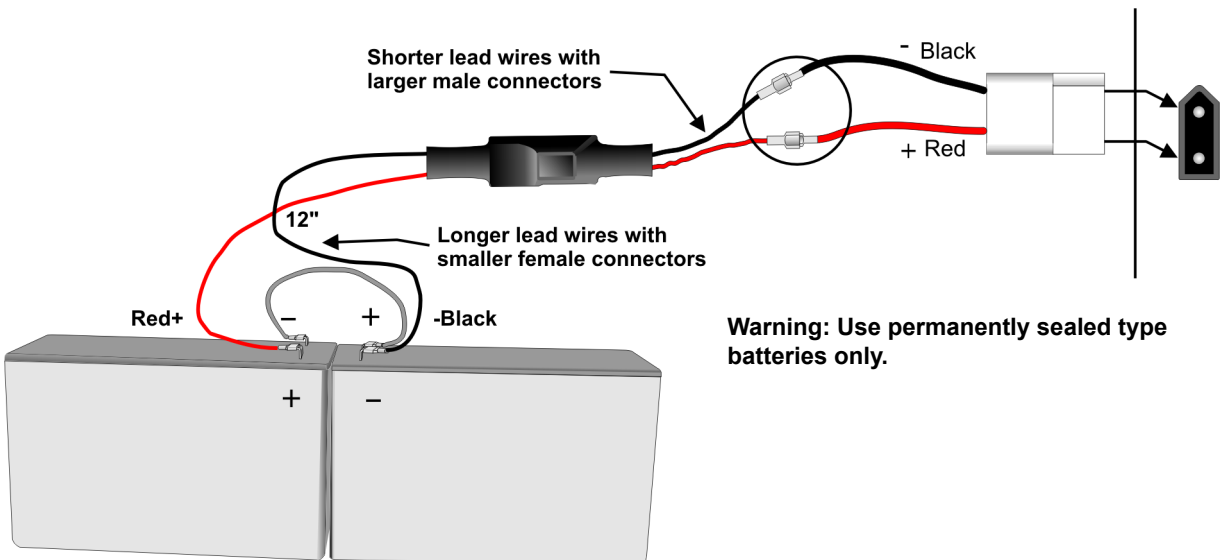

Figure 4-7 Battery Connection for ULC Installations

4.8 DIP Switch Settings

A 7-position DIP switch on the 5495 board allows you to select the following:

- How long the 5495 will wait before indicating a loss of AC.
- Which input (Input 1 or Input 2) will control the NACs.
- Which NACs to wire as Class A and Class B.
- Auxiliary power state.
- Which NACs to operate as steady, ANSI temporal, or sync. outputs

Refer to Figure 4-2 for the location of the DIP switch on the 5495 board.

4.8.1 Selecting the Standard Input/Output Configurations

Figure 4-8 and Figure 4-9 show the position of each switch for the non-synchronized input and output configurations. The position of Switches 4 and 5 does not affect the relationship of inputs to outputs.

Note: The 5495 checks switches 1, 2, 3, and 6 only when powering up the 5495. If you change these switch settings, you must remove both the AC power and the battery to make the 5495 recognize the new settings.

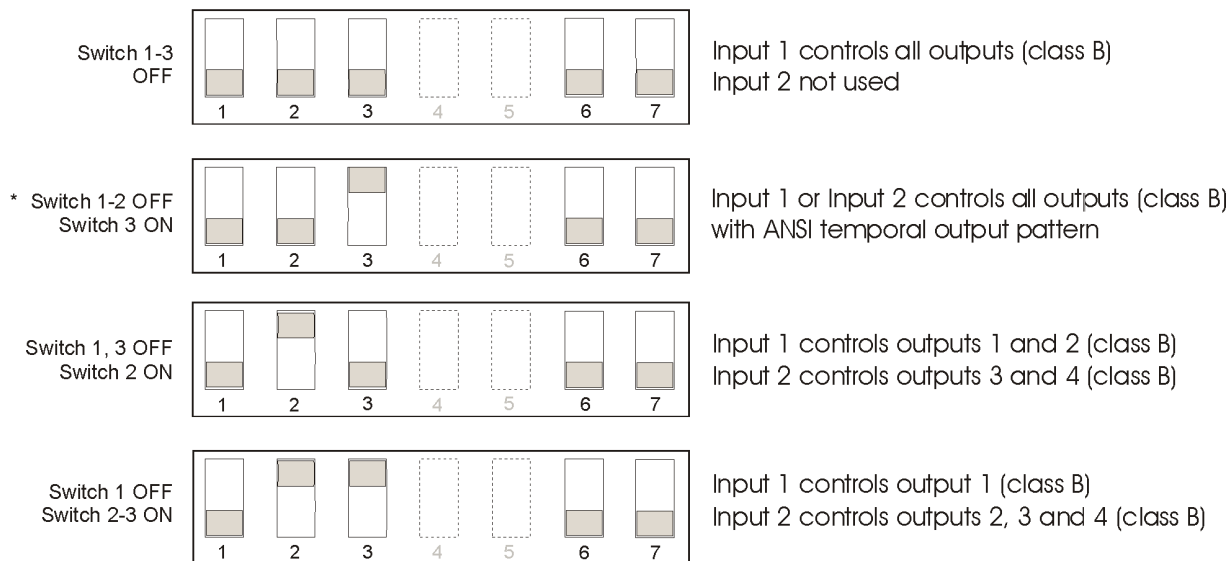

* See the following information about ANSI temporal-coded outputs

Figure 4-8 Setting DIP Switches 1-3

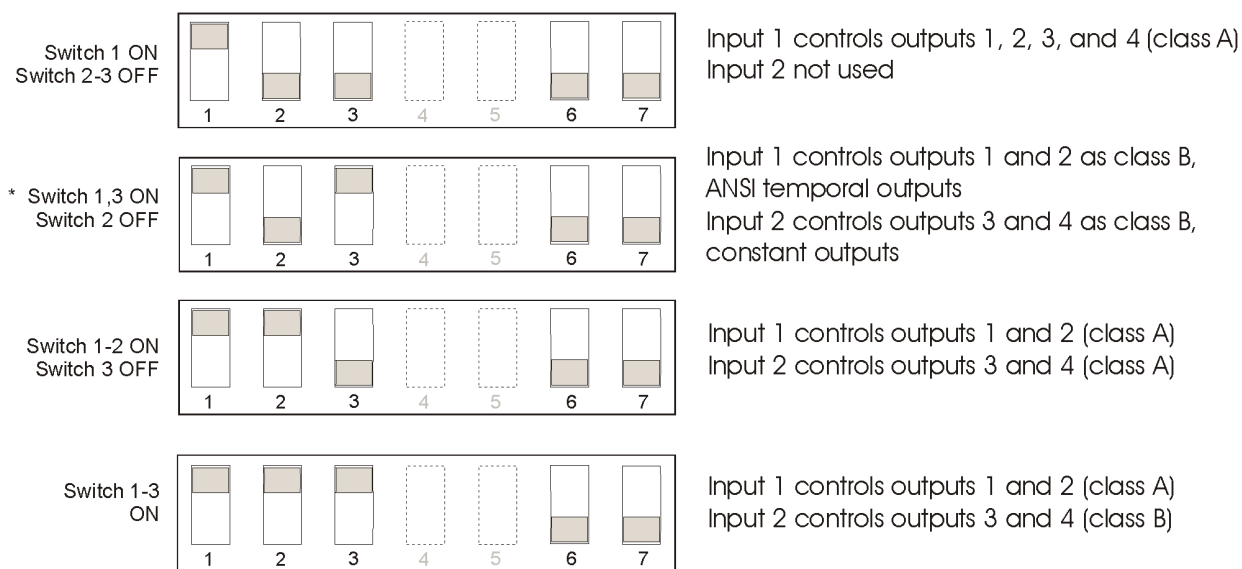

* See the following information about ANSI temporal-coded outputs

Figure 4-9 Setting DIP Switches 1-3 (Continued)

Note: For 100 ms input signal debounce with no synchronization DIP switches 6 and 7 must be turned On.

4.8.1.1 Input/Output Configurations That Select ANSI Temporal-Coded Outputs

The DIP switch settings marked with an asterisk (*) in Figure 4-8 and Figure 4-9 are designed to produce ANSI temporal-coded outputs from a constant input. The figures shown below compare the output patterns of configurations before and after the addition of this feature.

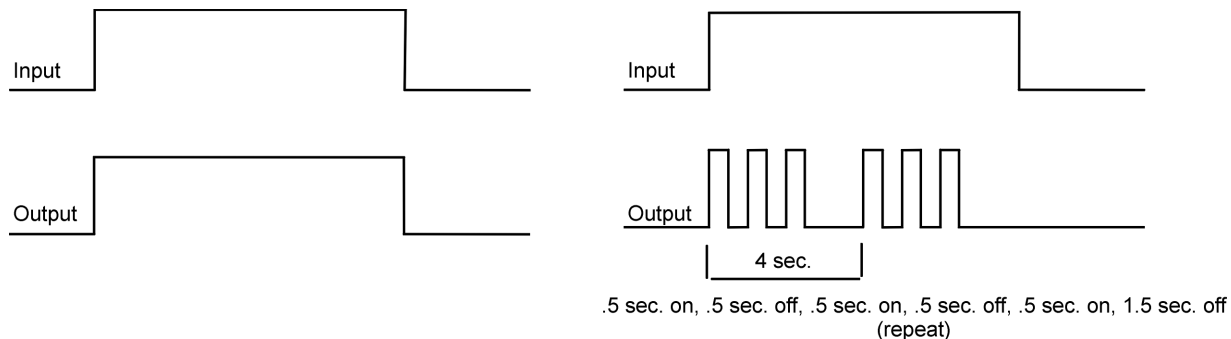

Standard 5495 Input to Output Relationship

Input/Output Relationship for ANSI Temporal-coded Options

With this new feature, a steady signal can produce the pattern shown above for panels not previously able to do so.

Note: *The 5495 can also produce temporal patterns if the inputs are non-ANSI temporal configurations.*

4.8.2 Selecting Synchronized Output Configurations

The following sections describe how to configure the 5495 as a synchronization power expander for Amseco, Faraday, Gentex, System Sensor, or Wheelock synchronized horn/strobe appliances.

Note: In order for the synchronization feature to operate properly, make sure you have set the DIP switches for the proper manufacturer. See Sections 4.8.2.1, 4.8.2.2, or 4.8.2.3.

Important!

For all synchronization options, input 1 is the strobe input and input 2 is the audible input. The signals to input 1 and input 2 must be DC signals for the synchronization patterns to work properly. When it is desired to activate both strobes and audibles, input 1 and input 2 must be active. If it is desired to only activate strobes, then input 1 must be active and input 2 must be inactive. The audible can be deactivated and reactivated at any time by changing the signal at input 2 as long as input 1 remains active. If input 1 is not active, then input 2 is ignored.

4.8.2.1 Selecting Synchronized Faraday Configurations

To select the input/outputs for Faraday synchronized appliances, set the DIP switches as shown in Figure 4-10.

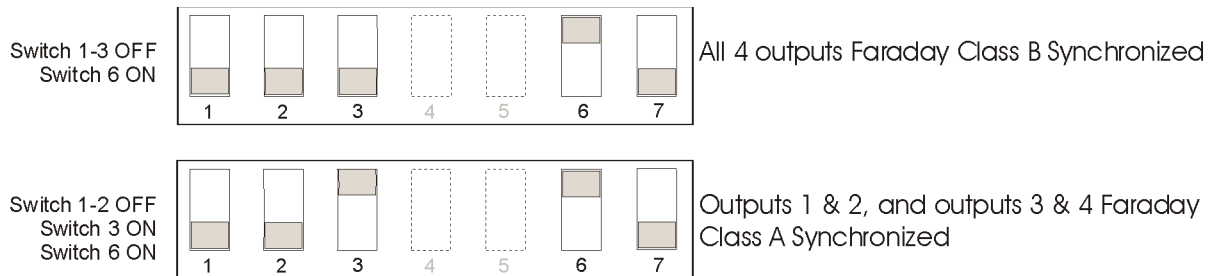

Figure 4-10 Faraday Synchronized Configurations

4.8.2.2 Selecting Synchronized Gentex Configurations

To select the input/outputs for Gentex synchronized appliances, set the DIP switches as shown in Figure 4-11.

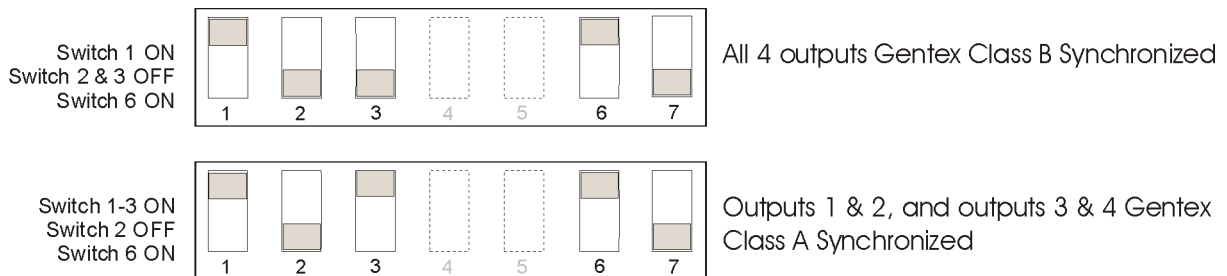

Figure 4-11 Gentex Synchronized Configurations

4.8.2.3 Selecting Synchronized System Sensor Configurations

To select the input/outputs for System Sensor synchronized appliances, set the DIP switches as shown in Figure 4-12.

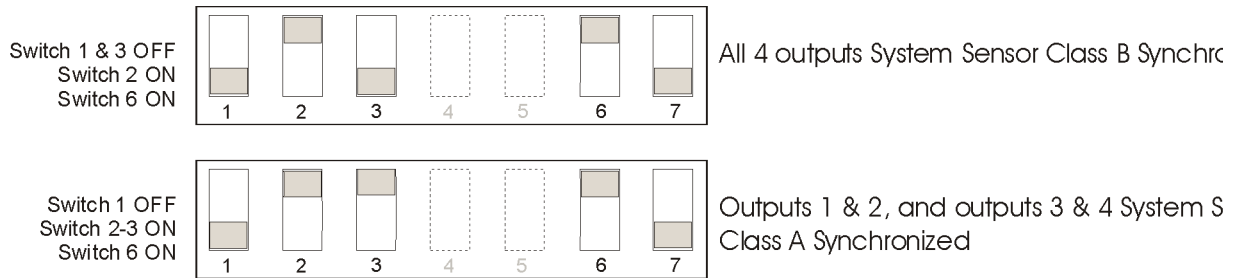

Figure 4-12 System Sensor Synchronized Configurations

4.8.2.4 Selecting Synchronized Wheelock Configurations

To select the input/outputs for Wheelock synchronized appliances, set the DIP switches as shown in Figure 4-13.

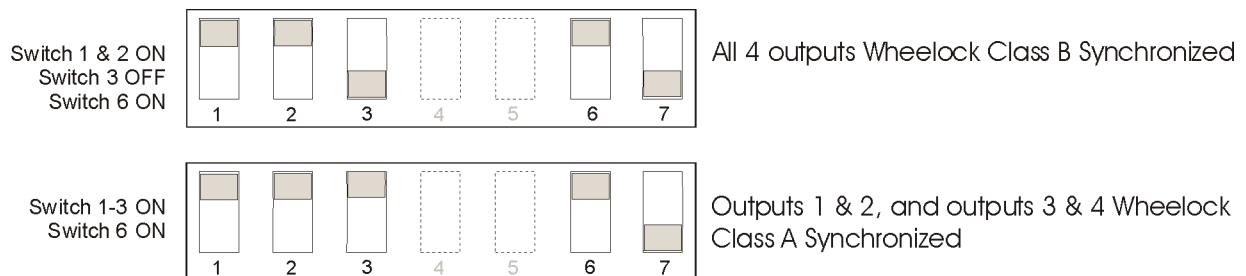

Figure 4-13 Wheelock Synchronized Configurations

4.8.2.5 Selecting Synchronized AMSECO Configurations

To select the input/outputs for AMSECO synchronized appliances, set the DIP switches as shown in Figure 4-14.

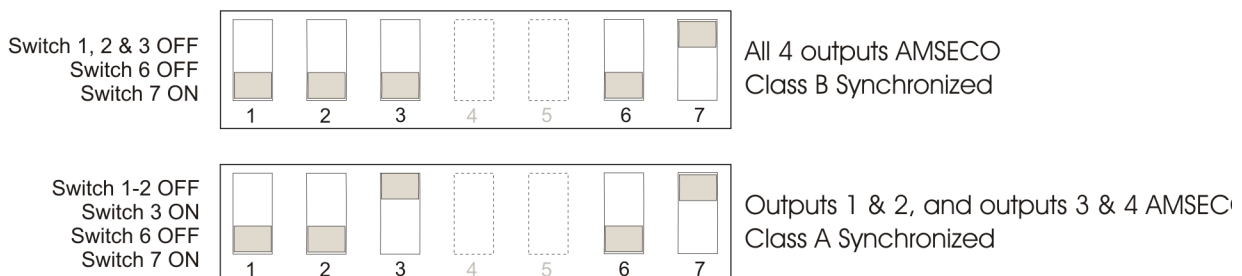

Figure 4-14 AMSECO Synchronized Configurations

4.8.3 Setting the Loss of AC Delay

Normal selection for reporting loss of AC is 3 hours.

The ON position is for test purposes only and the normal position for Switch 4 is OFF. For testing the Low AC reporting, you can temporarily turn Switch 4 ON without removing power.

Note: Remember to turn the switch OFF when testing is complete.

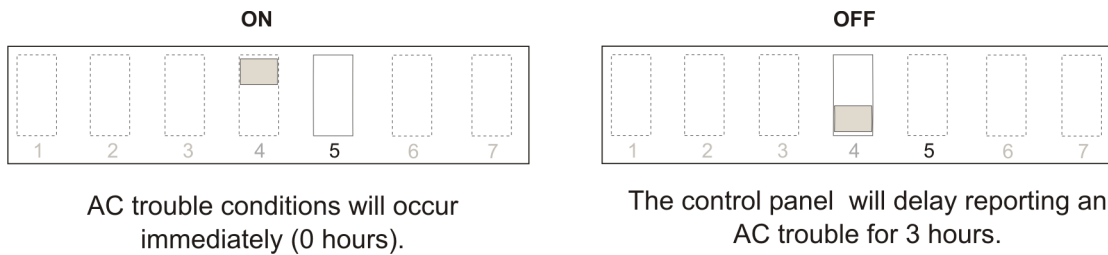

Figure 4-15 Setting DIP Switch 4

4.8.4 Setting the Auxiliary Output

Switch 5 on the DIP switch determines how the auxiliary power operates on the 5495.

The 5495 checks Switch 5 only when powering up the 5495. If you change this switch, you must remove both the AC power and the battery to force the 5495 to recognize the new switch setting.

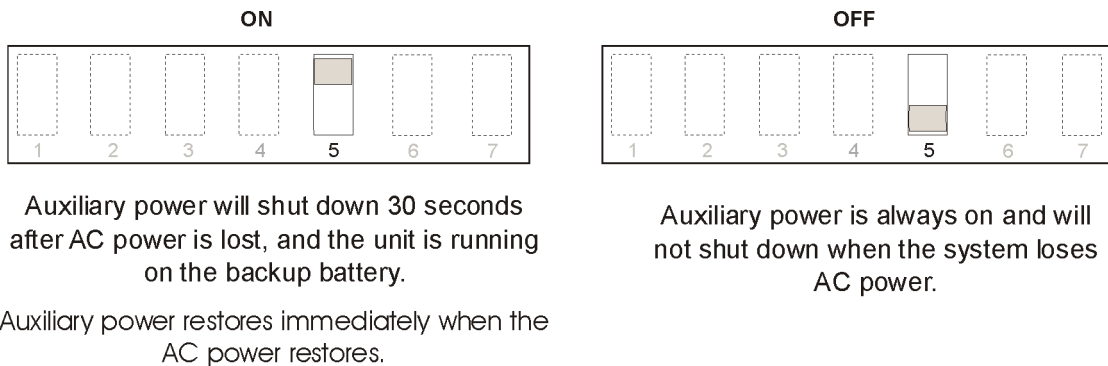

Figure 4-16 Setting DIP Switch 5

Section 5

Sample Applications

The drawings in this section show various 5495 configurations, including “daisy-chaining”.

5.1 Notification Power Applications

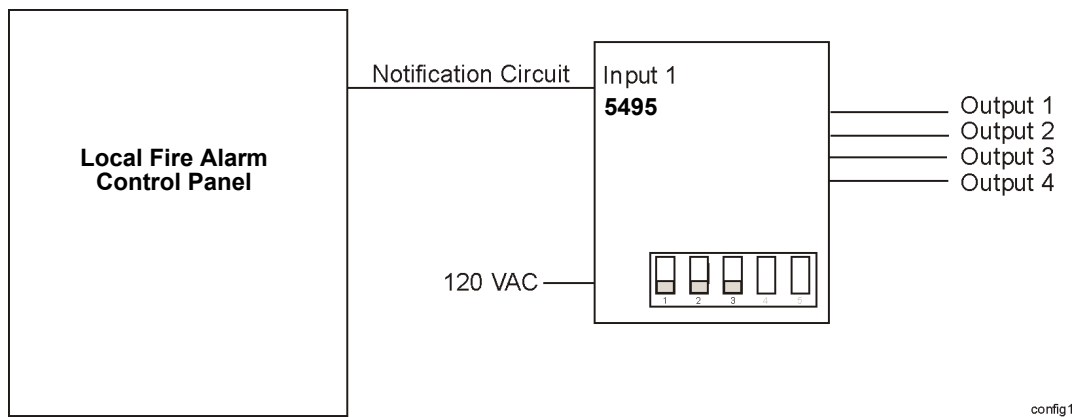

Figure 5-1 Input 1 Activates All Four Outputs

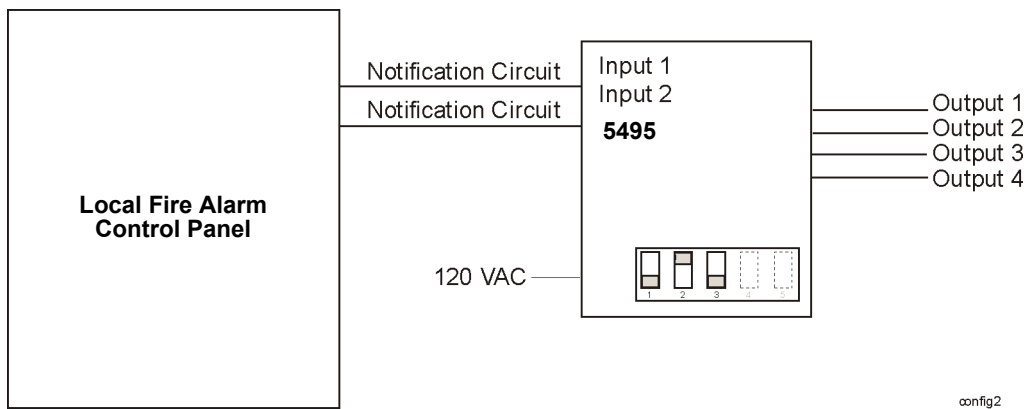

Figure 5-2 Input 1 Activates NACs 1 and 2; Input 2 Activates NACs 3 and 4

Note: When multiple power supplies are used with one control unit they will not sync with each other

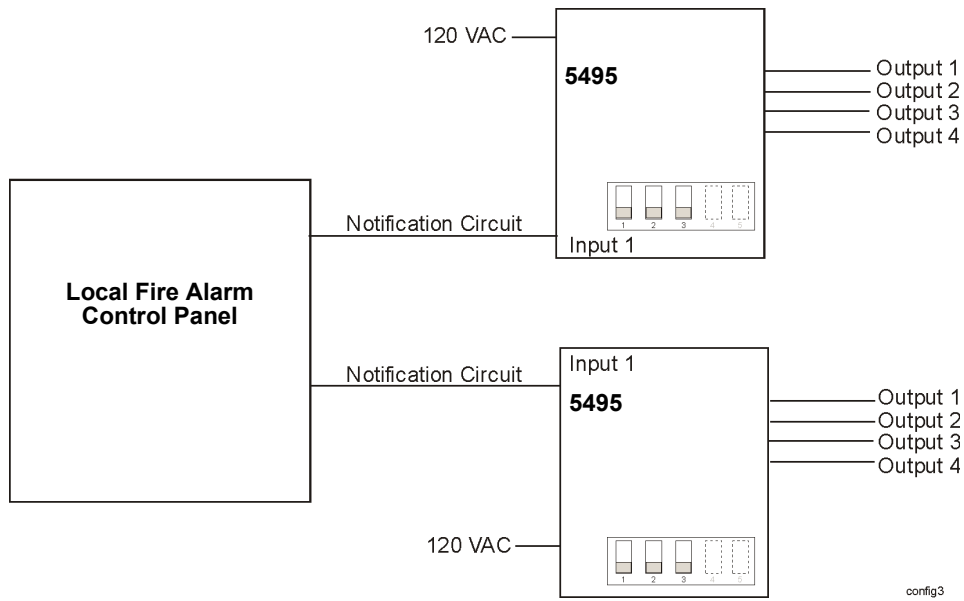

Figure 5-3 One Control Activating Two 5495s

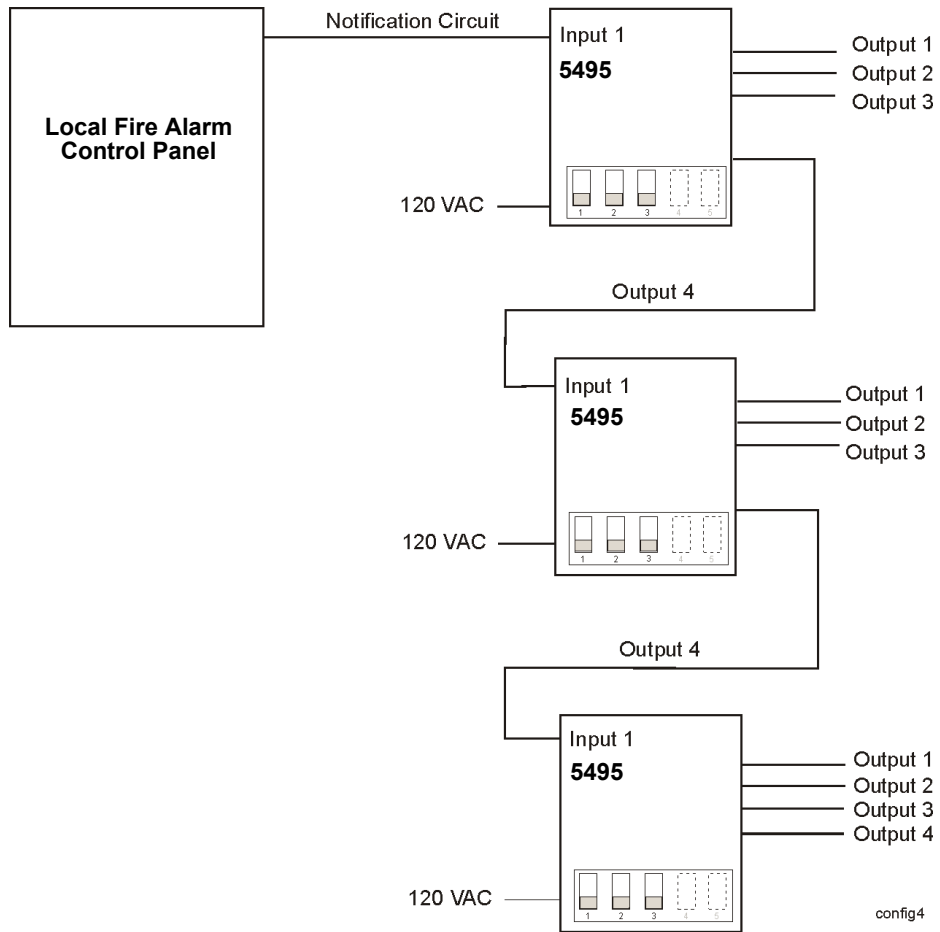

Figure 5-4 One Control Activating Three 5495s in Series

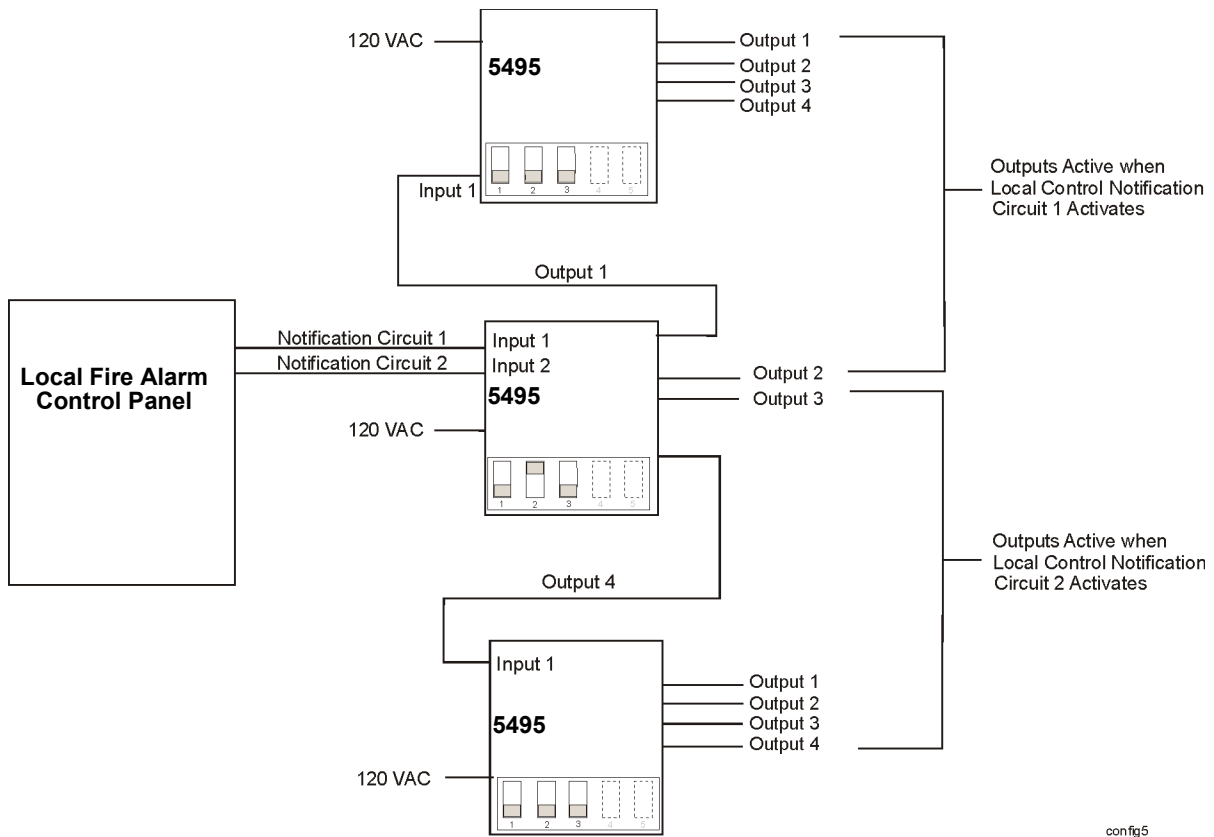
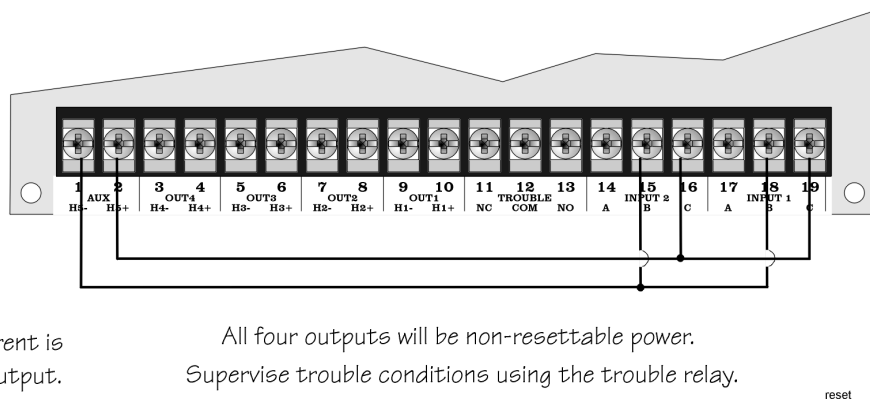

Figure 5-5 Each Control NAC Activates Five Output NACs

5.2 Non-Resettable Power Application

The 5495 provides a dedicated 3 A auxiliary power output that you can select as non-resettable (output is always on). See Section 4.8.4 for setting the auxiliary power. If you need more than 3 A, wire the inputs as shown in Figure 5-6.

This wiring provides up to 6 amps (max.) of continuous, non-resettable power (distributed among the four outputs).



Note:
maximum current is 3 amps per output.

All four outputs will be non-resettable power.
Supervise trouble conditions using the trouble relay.

Figure 5-6 Auxiliary Output Wiring for Non-Resettable Power

5.3 Door Holder Application

In a typical door holder application, the door holder power must be interrupted to close all fire doors under the following conditions:

- Any active alarm condition.
- AC power failure (to conserve battery power).

To close the fire doors in these situations, wire an N.C. programmable relay from the FACP in series with the auxiliary power to the door holders as shown in Figure 5-7.

The circuit shown in Figure 5-7 will provide up to 3 amps of door holder power. (See Section 5.2 if you need more than 3 amps of auxiliary power.) The power in this example is released when AC power is off for 30 seconds or more, or when the relay from the fire alarm control panel becomes open. You would have to use the equivalent of a programmable relay from a fire alarm control panel that is programmed to open under alarm conditions. See Section 4.8.4 for selecting auxiliary power options.

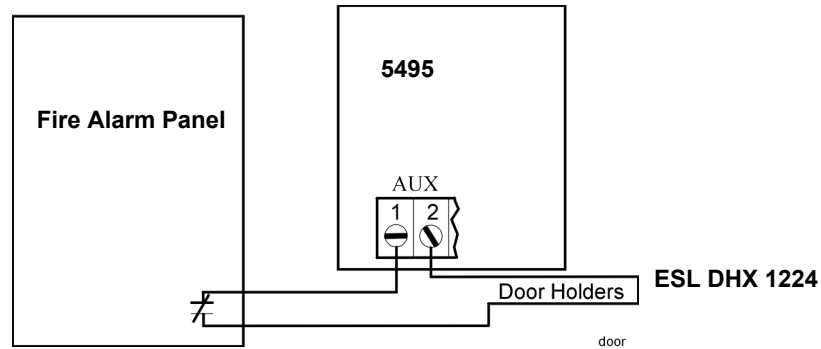

Figure 5-7 Door Holder Wiring Example

Section 6

Troubleshooting

Light-emitting diodes (LEDs) indicate fault conditions. This section describes the LED states.

6.1 LEDs

The eight LEDs indicate a fault in one of the circuits (either NACs 1 through 4, auxiliary power, earth fault, low AC, or battery). A fault in the LED's corresponding circuit will light the LED (labeled on the board). Their functions are as follows:

LED	Color	Description
OUT1	Yellow	When ON, output circuit 1 is in trouble or in an overcurrent state.
OUT2	Yellow	When ON, output circuit 2 is in trouble or in an overcurrent state.
OUT3	Yellow	When ON, output circuit 3 is in trouble or in an overcurrent state.
OUT4	Yellow	When ON, output circuit 4 is in trouble or in an overcurrent state.
AUX	Yellow	When ON, the auxiliary power output is in an overcurrent state.
FLT	Yellow	When ON, an earth ground fault on the unit exists.
BATT	Yellow	When ON, a low battery condition exists.
AC	Green	When OFF, there is no AC power to the unit. Under normal conditions, this LED is ON to indicate the presence of AC power.

See Figure 4-2 for locations of LEDs.

6.2 Trouble Conditions

Trouble Condition	What Happens
Low AC (AC input voltage is low or off for 6 hours or longer.)	Input 1 and Input 2 supervision circuits open after a 6 hour delay. The green AC LED turns off as soon as low AC or loss of AC occurs (does not wait 6 hours). The trouble relay is de-energized after a 6 hour delay. The trouble restores within 1 minute of the AC voltage restoring to a normal level.
Low Battery (Battery voltage is less than 21.4 VDC.)	Input 1 and Input 2 supervision circuits open. The yellow "BATT" LED lights. The trouble relay is de-energized. The trouble restores when battery voltage is greater than 22.4 VDC.
Earth Ground Fault (The earth terminal is connected to one of the positive or negative terminals on the output or auxiliary output circuits.)	Input 1 and Input 2 supervision circuits open. The yellow "FLT" LED lights. The trouble relay is de-energized. The trouble restores when the fault between the earth ground and one of the output circuit terminals is removed.
Power Limit At AUX (Current draw at the auxiliary power terminals is exceeding 3.0 amps.)	Power disconnects at the AUX terminal. Input 1 and Input 2 supervision circuits open. The yellow "AUX" LED lights. The trouble relay is de-energized. The trouble restores when the overcurrent condition no longer exists. When a circuit goes into a power limited state, it will reverse the polarity of the voltage at the terminals and verify the load. If it is more than 1k ohms, the power limit will self-restore. This does not automatically occur for some devices typically connected to auxiliary power. Power limit conditions do not restore in reverse polarity monitoring if the devices are not polarized (for example, some door holder devices). To allow automatic restores for power-limited auxiliary circuits, it is recommended that all non-polarized devices be polarized using a diode in series with each device.
Power-limited OUTPUT (Current draw at an output terminal is exceeding 3.0 amps.)	Power at the OUTPUT is disconnected. Input 1 and Input 2 supervision circuits open. The corresponding yellow LED lights. The trouble relay is de-energized. The trouble restores when the overcurrent condition no longer exists.
EOL supervision trouble (Equivalent resistance of the EOL resistor is outside the range 2k - 10k.)	Input 1 and Input 2 supervision circuits open. Corresponding yellow LED lights. The trouble relay is de-energized. Trouble restores if an EOL within (2k-10k) appears at the output terminals.

Note: While Input 1 & 2 are activated, Input 1 & 2 will not open to indicate a trouble or supervisory condition. Once the circuit is deactivated it will open to indicate a trouble or supervisory condition.

6.3 Earth Fault Resistance

Table 6-1 lists the earth fault resistance detection for each applicable terminal on the FACP.

Table 6-1: Earth Fault Resistance Values by Terminal

Function	Terminal Number	Terminal Label		Value (in kohms)
Auxiliary Devices	1	H5-	AUX	0
	2	H5+		0
Notification Appliance Circuit 4	3	H4-	OUT4	0
	4	H4+		0
Notification Appliance Circuit 3	5	H3-	OUT3	0
	6	H3+		0
Notification Appliance Circuit 2	7	H2-	OUT2	0
	8	H2+		0
Notification Appliance Circuit 1	9	H1-	OUT1	0
	10	H1+		0

6.4 Removing and Replacing the Control Panel

This section provides instruction on how to remove and replace the control panel if it is determined that the control panel needs to be repaired or replaced.

6.4.1 Removing the Control Panel

Follow these step to properly remove the control panel:

1. Remove the two heat sink screws. The heat sink screws are located on the top of the cabinet. See Figure 6-1.

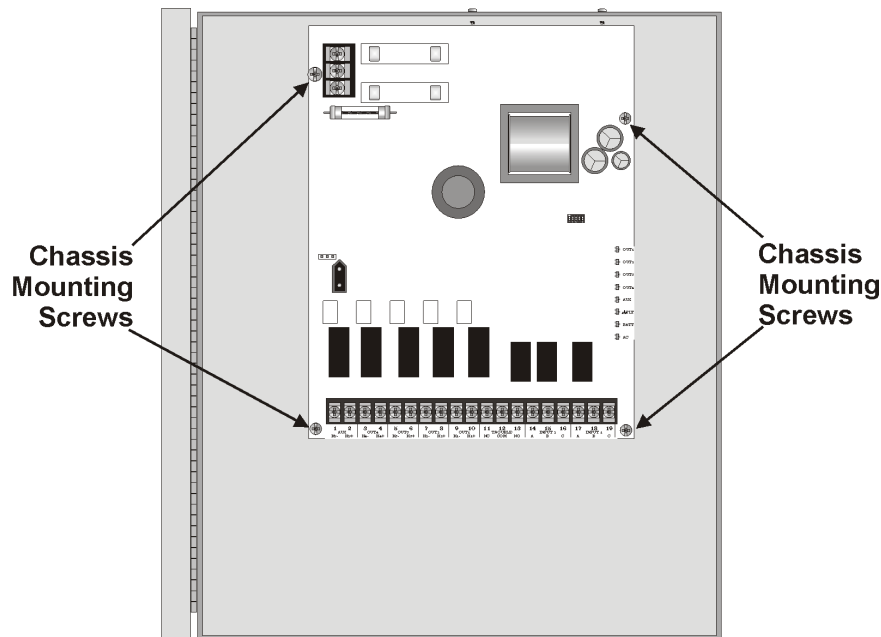

Figure 6-1 Mounting Screw Locations

2. Remove the four chassis mounting screws. See Figure 6-1 for chassis screw locations.
3. Carefully remove the control panel.

6.4.2 Replacing the Control Panel

Follow these steps to replace the control panel:

Note: Use a grounding strap when working with static sensitive components.

1. Align the control panel with the chassis mounting stand-offs. See Figure 6-1.
2. Insert the four chassis mounting screws (see Figure 6-1). Do not over tighten the chassis mounting screws.
3. Insert the two heat sink screws (see Figure 6-1). Do not over tighten the heat sink screws.

Note: The heat sink screws must be installed for proper heat dispersion of the power module's power supply.

Appendix A

UL Listed Notification Appliances

For proper operation, you must use polarized devices with a Model 7628 4.7k ohm EOL resistor on each circuit. All supervised notification appliances used with the 5495 must be polarized.

Note: Not all devices can use the Sync feature, be sure to check Table A-1 to ensure the device you have chosen will work with this feature. Synchronization is UL listed for multi-circuit operation.

A.1 Notification Appliances

Table A-1 below lists notification appliances compatible with the 5495. Appliances which can be synchronized indicate the type of sync available in the columns marked Audio and/or Visual.

Table A-1: Compatible Notification Appliances

Manufacturer	Model	Audio	Visual	Type
AMSECO	SH24W-153075	✓	✓	Horn/Strobe
	SAD24-153075		✓	Strobe
	SAD24-75110		✓	Strobe
	SL24W-75110		✓	Strobe
	SL24C-3075110		✓	Strobe
	SLB24-75		✓	Strobe
	RSD24-153075		✓	Strobe
	RSD24-75110		✓	Strobe
	SH24W-75110	✓	✓	Horn/Strobe
	SH24W-3075110	✓	✓	Horn/Strobe
	SHB24-75	✓	✓	Horn/Strobe
	SCM24W-153075	✓		Chimes/Strobe
	SCM24W-75110	✓		Chimes/Strobe
	SCM24C-3075110	✓		Chimes/Strobe
	SCM24C-177	✓		Chimes/Strobe
	H24W	✓		Horn
	H24R	✓		Horn
Faraday	446			Vibrating Bell
	476			Vibrating Bell
	477			Single Stroke Bell
	2700 -M, -R, -T, -Y, -Z			Strobe
	2701 Series			Strobe
	2705 Series			Strobe
	2820	✓	✓	Sync Temporal Horn/Strobe
	2821	✓	✓	Sync Temporal Horn/Strobe

Table A-1: Compatible Notification Appliances

Manufacturer	Model	Audio	Visual	Type
Faraday (cont.)	2824	✓	✓	Horn Strobe
	5333			Multi-Tone Horn)
	5336			Multi-Tone Horn/Strobe
	5337			Multi-Tone Horn/Strobe
	5338			Multi-Tone Horn/Strobe
	5343			Single Tone Horn/Strobe
	5346			Electronic Horn with Strobe
	5347			Electronic Horn with Strobe
	5348			Single Tone Horn/Strobe
	5373			8-Tone Horn/Strobe
	5376			8-Tone Horn/Strobe
	5377			8-Tone Horn/Strobe
	5378			8-Tone Horn/Strobe
	5383			8-Tone Horn/Strobe with Sync Strobe
	5386			8-Tone Horn/Strobe with Sync Strobe
	5387			8-Tone Horn/Strobe with Sync Strobe
	5388			8-Tone Horn/Strobe with Sync Strobe
	5508			Single Gang Sync Strobe
	5509			Strobe
	5510			Strobe
	5511			Strobe
	5512			Strobe
	5516			Strobe
	5517			Strobe
	5518			Strobe
	5519			Strobe
	5521			4" Square Sync Strobe
	5522			4" Square Sync Strobe
	6120			Horn
	6140			Horn
	6223			Horn
	6226			Horn/Strobe
	6227			Horn/Strobe
	6228			Horn/Strobe
	6243			Electron-Mechanical Horn
	6244			Electron-Mechanical Horn
	6245			Electron-Mechanical Horn
	6246			Electron-Mechanical Horn/Strobe
	6247			Electron-Mechanical Horn/Strobe
	6248			Electron-Mechanical Horn/Strobe
6300			Mini-Horn	

Table A-1: Compatible Notification Appliances

Manufacturer	Model	Audio	Visual	Type
Faraday (cont.)	6301			Mini-Horn
	6302			Mini-Horn
	6310			Mini-Horn/Strobe
	6311			Mini-Horn/Strobe
	6312			Mini-Horn/Strobe
	6314 Series -M, -R, -T, -Y, -Z			Strobe
	6320			Sync Mini Horn/Strobe
	6321			Sync Mini Horn/Strobe
	6322			Mini Horn/Sync Strobe
	6380			8-Tone Electronic Signal/Strobe
FCI	130-3117C			Mini Horn
	130-3147C			Mini Horn
	BLV-6			Vibrating Bell
	BLV-10			Vibrating Bell
	BLVCH			Vibrating Chime
	H12/24-FC			Horn
	H12/24W-FC			Horn
	H12/24K-FC			Horn
	HC12/24-FC			Horn
	HC12/24W-FC			Horn
	HC12/24K-FC			Horn
	P2415-FC			Horn/Strobe
	P2415W-FC			Horn/Strobe
	P2415K-FC			Horn/Strobe
	P241575-FC			Horn/Strobe
	P241575W-FC			Horn/Strobe
	P241575F-FC			Horn/Strobe
	P241575K-FC			Horn/Strobe
	P2430-FC			Horn/Strobe
	P2430W-FC			Horn/Strobe
	P2430K-FC			Horn/Strobe
	P2475-FC			Horn/Strobe
	P2475W-FC			Horn/Strobe
	P2475K-FC			Horn/Strobe
	P24110-FC			Horn/Strobe
	P24110W-FC			Horn/Strobe
	P24110K-FC			Horn/Strobe
	S2415-FC			Strobe
	S241575-FC			Strobe
	S241575W-FC			Strobe
S241575K-FC			Strobe	
S2430-FC			Strobe	

Table A-1: Compatible Notification Appliances

Manufacturer	Model	Audio	Visual	Type
FCI (cont.)	S2430W-FC			Strobe
	S2430K-FC			Strobe
	S2475-FC			Strobe
	S2475W-FC			Strobe
	S2475K-FC			Strobe
	S24110-FC			Strobe
	S24110W-FC			Strobe
	S24110K-FC			Strobe
Federal Signal	450			Horn
	VALS			Horn/Strobe
Gentex	GX90-4			Horn
	GX91	✓		MiniHorn Steady Tone
	GX93	✓		MiniHorn Temporal Tone
	GXS-4-15-1			Strobe
	GXS-4-1575			Strobe
	GX90S-4-15			Horn
	GX90S-4-1575			Horn
	HG124			Horn
	HS24-15	✓	✓	Horn/Strobe
	HS24-30	✓	✓	Horn/Strobe
	HS24-60	✓	✓	Horn/Strobe
	HS24-75	✓	✓	Horn/Strobe
	HS24-110	✓	✓	Horn/Strobe
	HS24-1575	✓	✓	Horn/Strobe
	SHG24-1575			Horn/Strobe
	SHG24-15			Horn/Strobe
	GCC24	✓	✓	Multi Candella Horn/Strobe Ceiling Mount
	GCCR24	✓	✓	Multi Candella Horn/Strobe Ceiling Mount
	GCS24		✓	Multi Candella Strobe Ceiling Mount
	GCSR24		✓	Multi Candella Strobe Ceiling Mount
	GEC-24-15	✓	✓	Horn/Strobes
	GEC-24-30	✓	✓	Horn/Strobes
	GEC-24-60	✓	✓	Horn/Strobes
	GEC-24-75	✓	✓	Horn/Strobes
	GEC-24-110	✓	✓	Horn/Strobes
	GEC-24-15/75	✓	✓	Horn/Strobes
	GEC-24-177	✓	✓	Horn/Strobes
	GEC3-24	✓	✓	Multi Candella Horn/Strobe
	GECR-24	✓	✓	Multi Candella Horn/Strobe
	GES-24-15		✓	Strobes

Table A-1: Compatible Notification Appliances

Manufacturer	Model	Audio	Visual	Type
Gentex (cont.)	GES-24-30		✓	Strobes
	GES-24-60		✓	Strobes
	GES-24-75		✓	Strobes
	GES-24-110		✓	Strobes
	GES-24-15/75		✓	Strobes
	GES-24-177		✓	Strobes
	GES3-24		✓	Multi Candella Strobe
	GESR-24		✓	Multi Candella Strobe
	GEH-24	✓		Horn
	GMH-24-X			Horn
	GMS-24-X			Horn/Strobe
	G0T24			Horn
	G0S24-X			Horn
	ST24-30		✓	Strobe
	ST24-60		✓	Strobe
	ST24-75		✓	Strobe
	ST24-110		✓	Strobe
	ST24-1575		✓	Strobe
	WGEC24-75	✓	✓	Weatherproof Horn/Strobe
	WGES24-75		✓	Weatherproof Strobe
WGMS-24-X			Horn/Strobe	
System Sensor	CHR	✓		Chime
	CHW	✓		Chime
	CHSR	✓	✓	2-Wire Chime/Strobe
	CHSW	✓	✓	2-Wire Chime/Strobe
	HR		✓	Horn
	HW		✓	Horn
	HRK		✓	Horn
	P2R	✓	✓	2-Wire Horn/Strobe
	P2R-P	✓	✓	2-Wire Horn/Strobe
	PC2R	✓	✓	2-Wire Horn/Strobe
	PC2R-P	✓	✓	2-Wire Horn/Strobe
	P2RH	✓	✓	2-Wire Horn/Strobe High Candela
	P2RH-P	✓	✓	2-Wire Horn/Strobe High Candela
	PC2RH	✓	✓	2-Wire Horn/Strobe High Candela
	PC2RH-P	✓	✓	2-Wire Horn/Strobe High Candela
	P2W	✓	✓	2-Wire Horn/Strobe
	P2W-P	✓	✓	2-Wire Horn/Strobe
	PC2W	✓	✓	2-Wire Horn/Strobe
PC2W-P	✓	✓	2-Wire Horn/Strobe	

Table A-1: Compatible Notification Appliances

Manufacturer	Model	Audio	Visual	Type	
System Sensor (cont.)	P2WH	✓	✓	2-Wire Horn/Strobe High Candela	
	P2WH-P	✓	✓	2-Wire Horn/Strobe High Candela	
	PC2WH	✓	✓	2-Wire Horn/Strobe High Candela	
	PC2WH-P	✓	✓	2-Wire Horn/Strobe High Candela	
	P2RK	✓	✓	2-Wire Horn/Strobe	
	PC2RK	✓	✓	2-Wire Horn/Strobe	
	P2RHK	✓	✓	2-Wire Horn/Strobe High Candela	
	PC2RHK	✓	✓	2-Wire Horn/Strobe High Candela	
	P4R	✓	✓	4-Wire Horn/Strobe	
	PC4R	✓	✓	4-Wire Horn/Strobe	
	P4RH	✓	✓	4-Wire Horn/Strobe High Candela	
	P4W	✓	✓	4-Wire Horn/Strobe	
	PC4W	✓	✓	4-Wire Horn/Strobe	
	P4WH	✓	✓	4-Wire Horn/Strobe High Candela	
	PC4WH	✓	✓	4-Wire Horn/Strobe High Candela	
	P4RK	✓	✓	4-Wire Horn/Strobe	
	PC4RK	✓	✓	4-Wire Horn/Strobe	
	P4RHK	✓	✓	4-Wire Horn/Strobe High Candela	
	PC4RHK	✓	✓	4-Wire Horn/Strobe High Candela	
	PC4RH	✓	✓	4-Wire Horn/Strobe High Candela	
	SR			✓	Strobe
	SR-P			✓	Strobe
	SCR			✓	Strobe
	SCR-P			✓	Strobe
	SRH			✓	Strobe High Candela
	SRH-P			✓	Strobe High Candela
	SCRH			✓	Strobe High Candela
	SCRH-P			✓	Strobe High Candela
	SW			✓	Strobe
	SW-P			✓	Strobe
	SCW			✓	Strobe
	SCW-P			✓	Strobe
	SWH			✓	Strobe High Candela
	SWH-P			✓	Strobe High Candela
	SCWH			✓	Strobe High Candela
	SCWH-P			✓	Strobe High Candela
	SRK			✓	Strobe
	SCRK			✓	Strobe
	SRHK			✓	Strobe High Candela
	SCRHK			✓	Strobe High Candela

Table A-1: Compatible Notification Appliances

Manufacturer	Model	Audio	Visual	Type
Wheelock	46T-G4-24-R	✓		Bell
	46T-G6-24-R	✓		Bell
	46T-G10-24-R	✓		Bell
	46T-G6-24-WS-24-HF-R	✓	✓	Strobe/Bell
	46T-G10-24-WS-24-HF-R	✓	✓	Strobe/Bell
	46T-G6-24-WH-24-HF-R	✓	✓	Strobe/Bell
	46T-G10-24-WH-24-HF-R	✓	✓	Strobe/Bell
	700IT-12\24-W-FR	✓	✓	Strobe Horn
	7002T-12\24-W-FR	✓	✓	Strobe Horn
	AES-DL1-R	✓		Multitone Horn
	AES-EL1-R	✓		Multitone Horn
	AES-DL1-WS-24-VF-R	✓		Multitone Horn
	AES-EL1-WS-24-VF-R	✓		Multitone Horn
	AES-DL1-WH-24-VF-R	✓		Multitone Horn
	AES-EL1-WH-24-VF-R	✓		Multitone Horn
	AES-DL1-WM-24-VF-R	✓		Multitone Horn
	AES-EL1-WM-24-VF-R	✓		Multitone Horn
	AH-24-R	✓		Horn
	AH-12	✓		Horn
	AH-24	✓		Horn
	AH-12WP	✓		Horn
	AH-24WP	✓		Horn
	AMT-241575W			✓

Table A-1: Compatible Notification Appliances

Manufacturer	Model	Audio	Visual	Type	
Wheelock (cont.)	AMT-24MCW		✓	Horn/Strobe	
	AH-24WP-R	✓		Horn	
	AMT-12\24-R	✓	✓	Strobe Horn	
	AMT-24-LS-VFR	✓	✓	Strobe Horn	
	AMT-24-LSM-VFR	✓	✓	Strobe Horn	
	AS-241575W	✓	✓	Horn/Strobe	
	AS-24MCC	✓	✓	Horn/Strobe	
	AS-24MCCH	✓	✓	Horn/Strobe	
	AS-24MCW	✓	✓	Horn/Strobe	
	AS-24MCWH	✓	✓	Horn/Strobe	
	ASWP-2475W	✓	✓	Horn/Strobe	
	AMT-24-IS-VFR	✓	✓	Strobe Horn	
	AS-24MCW-FR	✓	✓	Strobe Horn	
	AS-24MCW-FW	✓	✓	Strobe Horn	
	AS-2415W-FR	✓	✓	Strobe Horn	
	AS-2415C-FW	✓	✓	Strobe Horn	
	AS-241575W-FR	✓	✓	Strobe Horn	
	AS-2475C-FW	✓	✓	Strobe Horn	
	AS-24100C-FW	✓	✓	Strobe Horn	
	AS-2430W-FR	✓	✓	Strobe Horn	
	AS-2430C-FW	✓	✓	Strobe Horn	
	AS-2475W-FR	✓	✓	Strobe Horn	
	AS-24110W-FR	✓	✓	Strobe Horn	
	ASWP-2475W-FR	✓	✓	Strobe Horn	
	CH70-241575W			✓	Chime/Strobe
	CH70-24MCW			✓	Chime/Strobe
	CH70-24MCWH			✓	Chime/Strobe
	CH90-24MCC			✓	Chime/Strobe
	CH90-24MCCH			✓	Chime/Strobe
	HS-24	✓			Horn
	HS4-241575W	✓	✓		Horn/Strobe
	HS4-24MCW	✓	✓		Horn/Strobe
	HS4-24MCWH	✓	✓		Horn/Strobe
	MIZ-24S	✓			Mini Horn Strobe
	MT-121574W			✓	Mini Horn Strobe
	MT-241575W			✓	Mini Horn Strobe
	MT-24MCW			✓	Mini Horn Strobe
	MTWP-2475W			✓	Mini Horn Strobe
	NH-12/24	✓			Horn
	NS-121575W	✓	✓		Horn/Strobe

Table A-1: Compatible Notification Appliances

Manufacturer	Model	Audio	Visual	Type
Wheelock (cont.)	NS-241575W	✓	✓	Horn/Strobe
	NS-24MCW	✓	✓	Horn/Strobe
	RSS-121575W		✓	Strobe
	RSS-241575W		✓	Strobe
	RSS-24MCC		✓	Strobe
	RSS-24MCCR		✓	Strobe
	RSS-24MCCH		✓	Strobe
	RSS-24MCCHR		✓	Strobe
	RSS-24MCW		✓	Strobe
	RSS-24MCWH		✓	Strobe
	RSSP-121575W		✓	Strobe
	RSSP-241575W		✓	Strobe
	RSSP-24MCC		✓	Strobe
	RSSP-24MCCH		✓	Strobe
	RSSP-24MCW		✓	Strobe
	RSSP-24MCWH		✓	Strobe
	RSSWP-2475W		✓	Strobe
	CF-BF1			Chime
	CF-BF1-R			Chime
	CH-CF1			Chime
	CH-CF1-R			Chime
	CH-CF1-W			Chime
	CH-DF1			Chime
	CH-DF1-R			Chime
	CH-BF1-WS-24-HF-R			Strobe Chime
	CH-CF1-LS-24			Strobe Chime
	CH-CF1-MS-24			Strobe Chime
	CH-CF1-IS-24			Strobe Chime
	CH-CF1-LS-24-CFW			Strobe Chime
	CH-CF1-MS-24-CFW			Strobe Chime
	CH-CF1-IS-24-CFW			Strobe Chime
	CH-CF1-WS-24-CF-W			Strobe Chime
	CH-DF1-LS-24			Strobe Chime
	CH-DF1-MS-24			Strobe Chime
	CH-DF1-IS-24			Strobe Chime
	CH-DF1-LS-24-VFR			Strobe Chime
	CH-DF1-LSM-24-VFR			Strobe Chime
	CH-DF1-MS-24-VFR			Strobe Chime
	CH-DF1-IS-24-VFR			Strobe Chime
	CH-DF1-WM-24-VFR			Strobe Chime
	CH-DF1-WS-24-VF-R			Strobe Chime

Table A-1: Compatible Notification Appliances

Manufacturer	Model	Audio	Visual	Type
Wheelock (cont.)	EH-DL1-R			Electronic Horn
	EH-EL1-R Electronic Horn			Electronic Horn
	EHS-DL1-W-VF-R			Strobe Horn (single input)
	EHS-EL1-W-VF-R			Strobe Horn (single input)
	EH-DL1-WS-24-VF-R			Strobe Horn (dual input)
	EH-EL1-WS-24-VF-R			Strobe Horn (dual input)
	EH-DL1-WH-24-VF-R			Strobe Horn (dual input)
	EH-EL1-WH-24-VF-R			Strobe Horn (dual input)
	EH-DL1-WM-24-VF-R			Strobe Horn (dual input)
	EH-EL1-WM-24-VF-R			Strobe Horn (dual input)
	HSW-24-HFR			Remote Strobe
	HS2W-24-HFR			Remote Strobe
	HSPW-24-HFR			Remote Strobe
	IS-24-VFR			Remote Strobe
	IS1-24-VFR			Remote Strobe
	IS3-24-VFR			Remote Strobe
	ISP-24-HFR			Remote Strobe
	LS-24-VFR			Remote Strobe
	LS1-24-VFR			Remote Strobe
	LS3-24-VFR			Remote Strobe
	LSP-24-HFR			Remote Strobe
	LSM-24-VFR			Remote Strobe
	LS1M-24-VFR			Remote Strobe
	LS3M-24-VFR			Remote Strobe
	LSPM-24-VFR			Remote Strobe
	MS-24-VFR			Remote Strobe
	MS1-24-VFR			Remote Strobe
	MS3-24-VFR			Remote Strobe
	MSP-24-HFR			Remote Strobe
	MB-G6-24-R			Motor Bell
	MB-G10-24-R			Motor Bell
	MBS-G6-24-W-HF-R			Motor Bell with Strobe
	MBS-G10-24-W-HF-R			Motor Bell with Strobe
	MIZ-24-R			Mini-Horn
	MIZ-24-W			Mini-Horn
	MIZ-24-LS-VFR			Mini-Horn/Strobe
	MIZ-24-LSM-VFR			Mini-Horn/Strobe
	MIZ-24-MS-VFR			Mini-Horn/Strobe
	MIZ-24-HSW-HFR			Mini-Horn/Strobe
	MIZ-24-IS-VFR			Mini-Horn/Strobe
	MIZ-24-WS-VF-R			Mini-Horn/Strobe
	MIZ-24-WS-VF-W			Mini-Horn/Strobe

Table A-1: Compatible Notification Appliances

Manufacturer	Model	Audio	Visual	Type
Wheelock (cont.)	MIZ-24-WH-VF-W			Mini-Horn/Strobe
	MIZ-24-WM-VF-W			Mini-Horn/Strobe
	MT-12/24-R			Strobe Horn
	MT-24-LS-VFR			Strobe Horn
	MT-24-LSM-VFR			Strobe Horn
	MT-24-MS-VFR			Strobe Horn
	MT-24-IS-VFR			Strobe Horn
	MT-24-SL-VFR			Strobe Horn
	MT-24-SLM-VFR			Synch. Multitone Strobe
	MT-24-WM			Strobe
	MT-24-WM-VFR			Horn
	NS-24MCM-FR	✓	✓	Horn Strobes
	NS-24MCW-FW	✓	✓	Horn Strobes
	NS-2415W-FR	✓	✓	Horn Strobes
	NS-241575W-FR	✓	✓	Horn Strobes
	NS-2430W-FR	✓	✓	Horn Strobes
	NS-2475W-FR	✓	✓	Horn Strobes
	NS-24110W-FR	✓	✓	Horn Strobes
	NS4-24MCW-FR	✓	✓	Horn Strobes
	NS4-24MCW-FW	✓	✓	Horn Strobes
	NS4-241575W-FR	✓	✓	Horn Strobes
	NH-12/24-R	✓		Horn
	RS-2415-HFR			Strobe
	RSP-2415-VFR			Strobe
	RS-241575-VFR			Strobe
	RSP-241575-VFR			Strobe
	RS-2430-VFR			Strobe
	RS-2430-HFR			Strobe
	RS-2475-VFR			Strobe
	RSP-2475-HFR			Strobe
	RS-24110-HFR			Strobe
	RSP-24110-HFR			Strobe
	SL-24-VFR			Synchronized Remote Strobe
	SL1-24-VFR			Synchronized Remote Strobe
	SL3-24-VFR			Synchronized Remote Strobe
	SLP-24-VFR			Synchronized Remote Strobe
	SLM-24-VFR			Synchronized Remote Strobe
	SL1M-24-VFR			Synchronized Remote Strobe
	SL3M-24-VFR			Synchronized Remote Strobe
	SLPM-24-VFR			Synchronized Remote Strobe
SHW-24-VFR			Synchronized Remote Strobe	
SH2W-24-VFR			Synchronized Remote Strobe	

Table A-1: Compatible Notification Appliances

Manufacturer	Model	Audio	Visual	Type
Wheelock (cont.)	SHPW-24-VFR			Synchronized Remote Strobe
	SR-2415-VFR			Sync Strobe
	SRP-2415-HFR			Sync Strobe
	SR-241575-VFR			Sync Strobe
	SRP-241575-VFR			Sync Strobe
	SR-2475-VFR			Sync Strobe
	SR-2475-HFR			Sync Strobe
	SR-24110-HFR			Sync Strobe
	SRP-24110-HFR			Sync Strobe
	V700IT-12\24-W-FR			Strobe Horn
	WM3T-24-FR			Remote Strobe
	WM3T-24-VFR			Remote Strobe
	WS1T-24-FR			Strobe
	WS3T-24-FR			Strobe
	WST-24-FR			Strobe

Silent Knight Fire Product Warranty and Return Policy

General Terms and Conditions

- All new fire products manufactured by Silent Knight have a limited warranty period of 18 months from the date of manufacture against defects in materials and workmanship. See limited warranty statement for details.
- This limited warranty does not apply to those products that are damaged due to misuse, abuse, negligence, exposure to adverse environmental conditions, or have been modified in any manner whatsoever.

Repair and RA Procedure

- All products that are returned to Silent Knight for credit or repair require a RA (Return Authorization) number. Call Silent Knight Customer Service at 800-446-6444 or 763-493-6435 between 8:00 A.M. and 4:45 P.M. CST, Monday through Friday to obtain a return authorization number. Silent Knight Technical Support is available at 800-328-0103 between 8:00 A.M. and 5:00 P.M. CST, Monday through Friday.
- RA number must be prominently displayed on the outside of the shipping box. See return address example under Advanced Replacement Policy.
- Include a packing slip that has the RA number, a content list, and a detailed description of the problem should be included with each return.
- All products returned to Silent Knight must be sent freight pre-paid. After product is processed, Silent Knight will pay for shipping product back to customer via UPS ground.
- Return the Silent Knight product circuit board only. Products that are returned in cabinets will be charged an additional \$50 to cover the extra shipping and handling costs over board only returns. **Do not return batteries.** Silent Knight has the authority to determine if a product is repairable. Products that are deemed un-repairable will be returned to the customer.
- Product that is returned that has a board date code more than 18 months from date of manufacture will be repaired and the customer will be assessed the standard Silent Knight repair charge for that model.

Advanced Replacement Policy

- Silent Knight offers an option of advance replacement for fire product printed circuit boards that fail during the first 6 months of the warranty period.
- For advance replacement of a defective board contact your local Silent Knight Distributor or call Silent Knight at 800-446-6444 or 763-493-6435 to obtain a RA (Return Authorization) number and request advanced replacement.
- Customers without a Silent Knight account must use a MasterCard, Visa, or American Express credit card to get an advance replacement.
- A new or refurbished board will be shipped to the customer. The customer will initially be billed for the replacement board but a credit will be issued after the repairable board is received at Silent Knight. All returned products must comply with the guidelines described under “General Terms and Conditions”.

- The defective board must be returned within 30 days of shipment of replacement board for customer to receive credit. No credit will be issued if the returned board was damaged due to misuse or abuse.
- Repairs and returns should be sent to:
Silent Knight
Attn: Repair Department
7550 Meridian Circle Suite 100
Maple Grove, MN 55369-4927
RA Number: _____

Limited Warranty

Silent Knight warrants products manufactured by it to be free from defects in materials and workmanship for eighteen (18) months from the date of manufacture, under normal use and service. Products are date stamped at time of manufacture. The sole and exclusive obligation of Silent Knight is to repair or replace, at its option, free of charge for parts and labor, any part that is defective in materials or workmanship under normal use and service. All returns for credit are subject to inspection and testing at the factory before actual determination is made to allow credit. Silent Knight does not warrant products not manufactured by it, but assigns to the purchaser any warranty extended by the manufacturer of such products. This warranty is void if the product is altered or repaired by anyone other than Silent Knight or as expressly authorized by Silent Knight in writing, or is serviced by anyone other than Silent Knight or its authorized distributors. This warranty is also void if there is a failure to maintain the products and systems in which they operate in a proper and workable manner. In case of defect, secure a Return Material Authorization form from our Return Authorization Department.

This writing constitutes the only warranty made by Silent Knight , with respect to its products. Silent Knight , does not represent that its products will prevent any loss by fire or otherwise, or that its products will in all cases provide the protection for which they are installed or intended. Buyer acknowledges that Silent Knight , is not an insurer and assumes no risk for loss or damages or the cost of any inconvenience, transportation damage, misuse, abuse, accident or similar incident.

SILENT KNIGHT GIVES NO WARRANTY, EXPRESS OR IMPLIED, OF MERCHANTABILITY, FITNESS FOR ANY PARTICULAR PURPOSE, OR OTHERWISE WHICH EXTENDS BEYOND THE DESCRIPTION ON THE FACE HEREOF. UNDER NO CIRCUMSTANCES SHALL SILENT KNIGHT BE LIABLE FOR ANY LOSS OF OR DAMAGE TO PROPERTY, DIRECT, INCIDENTAL OR CONSEQUENTIAL, ARISING OUT OF THE USE OF, OR INABILITY TO USE SILENT KNIGHT ALARM PRODUCTS. FURTHERMORE, SILENT KNIGHT SHALL NOT BE LIABLE FOR ANY PERSONAL INJURY OR DEATH WHICH MAY ARISE IN THE COURSE OF, OR AS A RESULT OF, PERSONAL, COMMERCIAL OR INDUSTRIAL USE OF ITS PRODUCTS.

This warranty replaces all previous warranties and is the only warranty made by SILENT KNIGHT. No increase or alteration, written or verbal, of the obligation of this warranty is authorized.

"SILENT KNIGHT" is a registered trademark.



**SILENT
KNIGHT**

by Honeywell

7550 Meridian Circle
Maple Grove, MN 55369-4927
763-493-6455
1-800-328-0103
Fax: 763-493-6475

© 2006 Silent Knight