



**SILENT
KNIGHT**

by Honeywell

5824 Serial/Parallel Printer Interface Module Installation Instructions

The 5824 Serial/Parallel Printer Interface Module (5824) connects a compatible fire alarm control panel (FACP) directly to a printer to print event history. You can also print system event logs in real time and detector status from addressable FACP.

Note: Installation and wiring of this device must be done in accordance with NFPA 72 and local ordinances.

Specifications

Operating Voltage: 24 VDC

Current (Alarm and Standby): 50 mA

Max Per FACP Addressable FACP: 8; 5208 FACP: 1

Ambient Temperature: 32°F to 120°F (0°C to 49°C)

Max Wiring Distance from FACP: 6000 ft. (1829 m)

Mounting: Surface

Dimensions: 6"W x 7-3/4"H x 1-7/16"D
(15.2 cm W x 19.7 cm H x 3.7 cm D)

Compatibility

The 5824 is compatible with all Silent Knight addressable FACP and with the 5208 conventional FACP.

Mounting

The 5824 comes in a plastic enclosure which must be mounted inside the annunciator or accessory cabinet.

To mount the 5824 plastic enclosure into the appropriate cabinet:

1. Remove the 5824 cover. Use a small screw driver if necessary.
2. Remove the 5824 circuit board from the base by pushing outward on the base snap retaining tabs and lifting the circuit board out.

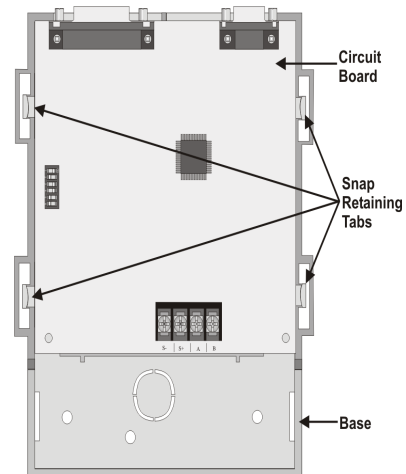

Figure 1: 5824 Circuit Board And Plastic Base

3. Mount the plastic base into the appropriate accessory cabinet.
4. Replace the circuit board in the plastic base.

Note: It may be necessary to connect the wiring to the circuit board before the board is replaced into the base.

Wiring to a FACP

See Table 1 and Figure 2 to terminate the wiring.

Table 1: 5824 to FACP Connections

5824 Terminals	FACP SBUS Terminals
B	B
A	A
S+	+
S-	-

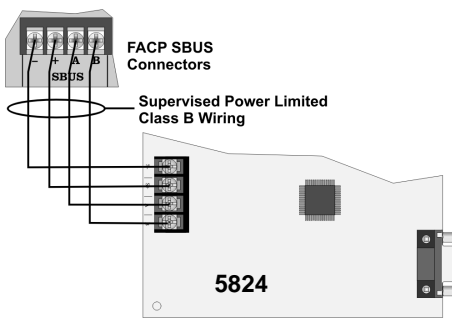

Figure 2: Wiring the 5824 to the FACP

Setting DIP Switches

Each 5824 connected to a compatible FACP requires an ID number which is set using the DIP switches on the 5824 circuit board. Refer to Figure 3 to see how to position the DIP switches for the desired ID number. See the FACP installation manual for specific information on device ID assignments.



Figure 3: 5824 DIP Switch Settings Used to Set the ID Number

Connecting to a Printer

You need to provide either a pass-through 9-pin serial cable or a 25-pin-to-Centronics® parallel cable to connect the 5824 to the printer. Using the appropriate printer cable, connect the cable to the serial or parallel port on the 5824, and then connect it to the printer.

For More Information

This document is for quick reference. For more information, refer to the FACP installation manual.



12 Clintonville Road
 Northford, CT 06472-1610 USA
 203-484-7161
 Fax: 203-484-7118
 www.silentknight.com

© 2010 Honeywell International Inc.